

BLÜCHER® EuroPipe

Installation . Maintenance . Material properties

Stainless Steel Drainage Systems

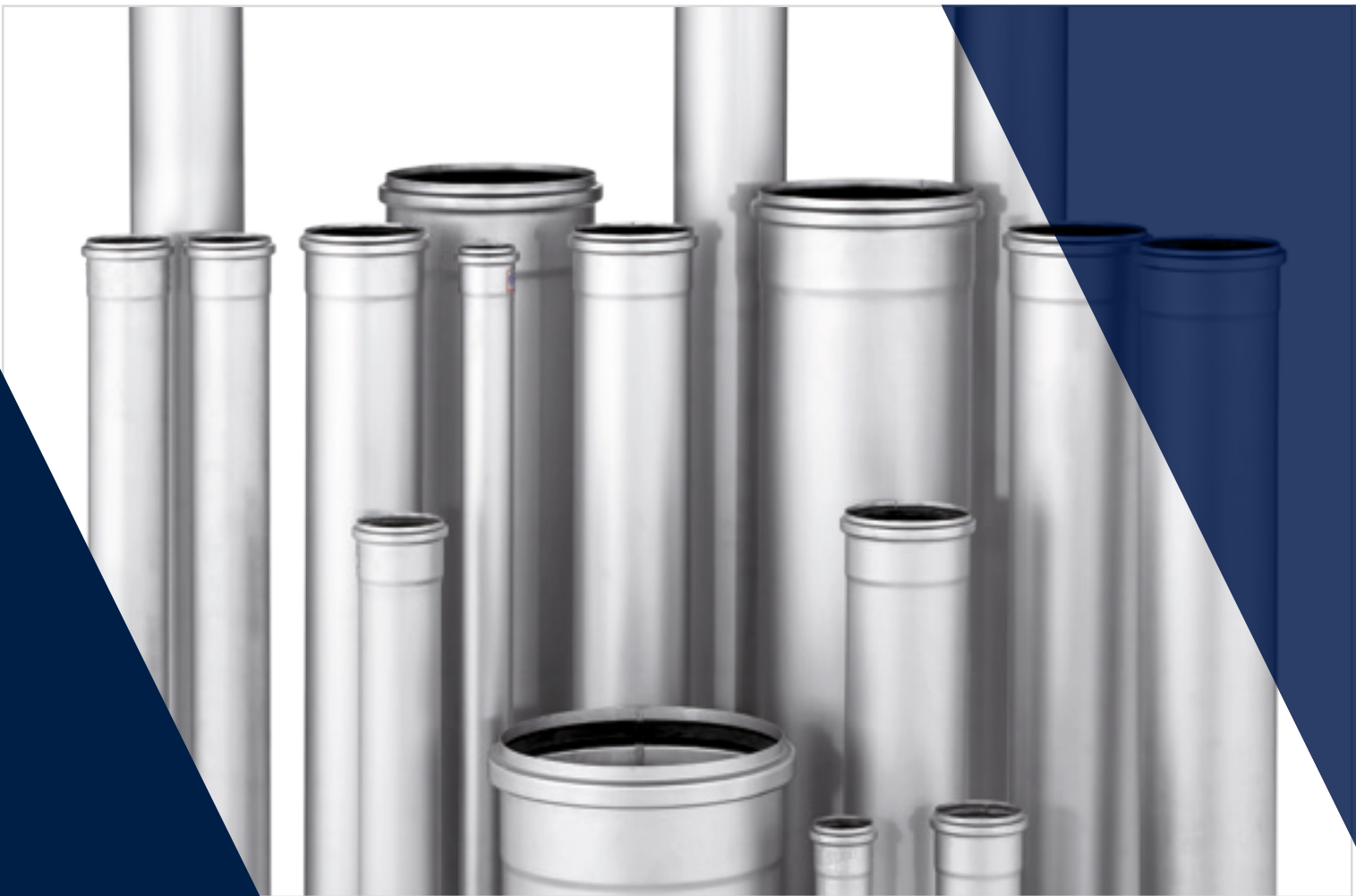

BLÜCHER®

A WATTS Brand

■ QUALITY ASSURANCE – ISO 9001

In the more than 35 years during which we at BLÜCHER have been developing and manufacturing stainless steel drainage systems, we have always done our best to make quality products, not merely from a design perspective, but equally from the perspective of function and durability.

BLÜCHER gives high priority to quality assurance, and all our production and quality assurance are in accordance with the internationally recognised ISO 9001 standard.

We operate with both external and internal quality assurance.

■ The ISO 9001 standard requires:

- the provision of documentation that controls are exercised at the level of administrative systems, development and design, purchasing, acceptance inspection, production, inspection of finished goods, stocks, sales, quality assurance and training.

■ External quality assurance

Several times a year, we have unannounced visits from representatives of Danish and foreign control bodies.

The auditors take a number of randomly selected pipes and fittings from our stocks or production and test them in accordance with the standards and approval criteria of the individual countries.

All control bodies are certified by the relevant national authorities to audit BLÜCHER's products.

■ Internal quality assurance

1. Internal quality control at BLÜCHER starts in the selection of our suppliers. All suppliers must be able to document their compliance with our requirements of quality and supply efficiency.
2. Every single delivery of stainless steel is accompanied by a material certificate, documenting the compliance of the stainless steel with the requirements specified by BLÜCHER.
3. All materials delivered to BLÜCHER must undergo admission checks. Only if the material delivered is in compliance with the requirements specified can it be passed on for production.
4. The stainless pipes are produced in a fully automated pipe mill. The sheet material, in the shape of coils, is introduced into the pipe mill, in which it is shaped by means of rollers into a pipe profile. The pipe is then welded with a longitudinal seam.
5. Upon welding, the longitudinal seam is checked with a circulating current device for detection of welding faults. In case of faults, the computer-controlled pipe mill automatically takes care of sawing out the defective pipe section and discarding it.
6. From the production department, all pipes and fittings proceed to the final surface treatment in the pickling plant. This surface treatment, tested by the Danish testing laboratory Korrosions-centralen, ensures that the pipes may be placed directly in the ground without additional protection.
7. During production of pipes and fittings, quality control takes place, which is meticulously registered in control journals. Before the fittings leave the production department, all elements are pressure-tested at 0.5 bar.
8. After the pickling, pipes and fittings proceed to the finishing department, where lip seals, among other things, are installed in the socket groove. At the same time, the elements are marked with approval markings, so that the elements may be identified at all times.
9. After finishing, pipes and fittings proceed to the central storage department. Here, the individual orders are packaged safely, in order to reach the customer undamaged.

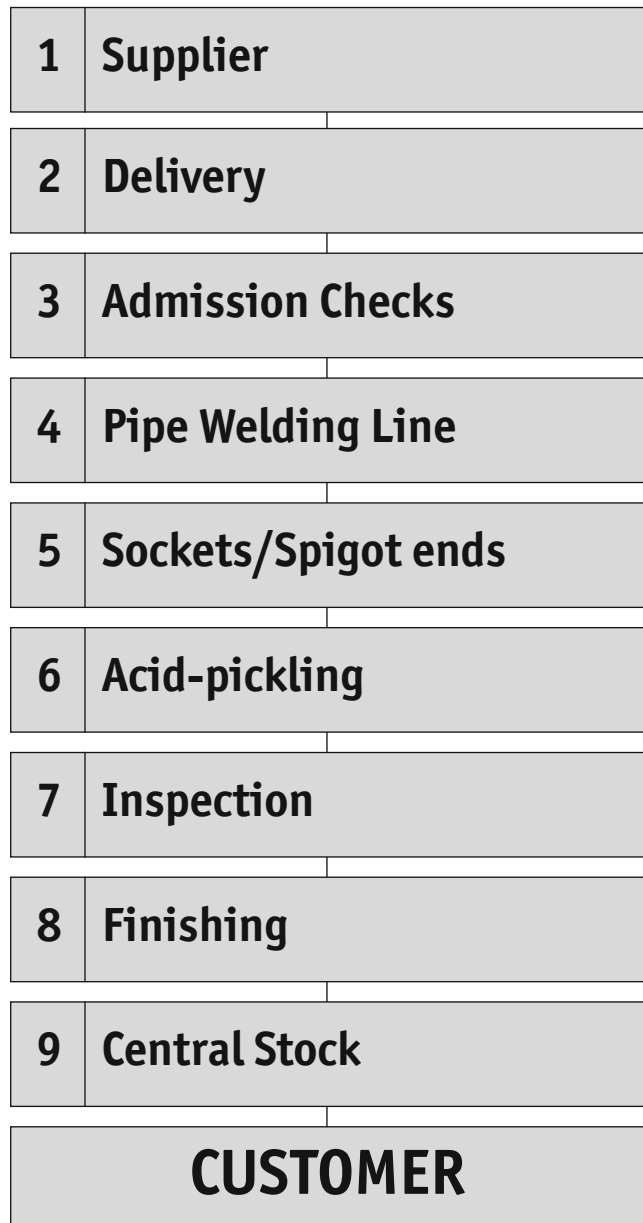

■ CONTENTS:

1. Presentation of BLÜCHER

Presentation of technical brochure	2
The company	2
Product range	2
General advantages	2

2. Presentation of BLÜCHER® EuroPipe

Uses	3
Description of product range	3
Advantages	3
Dimensions	3

3. Material properties

What is stainless steel?	4
Importance of alloying elements	4
Why is steel "stainless"?	4
Properties	
- Corrosion resistance	5
- Resistance to fire	5
- Environment	5
- Protection against blockages	5
- Hygiene	5
- Resistance to deformation	5
- Resistance to thermal stress	5
- Weight	5
Enhanced finish	6
Chemical resistance table	7
Push-fit socket joint	8

4. Maintenance

- General	9
- Preventive maintenance	9
- Maintenance of a BLÜCHER® EuroPipe installation	10
- Discolouration	10
- Preventive arrangements	10
- How to remove stains and discolouration	11

5. Installation – general

Cutting of pipes	12
- Manual cutter	12
- Electric cutter	12
Joining of socket/spigot end	12
Insertion depth in sockets	12

6. Installation – sewerage system

Min. and max. soil covering	13
Below-ground installation	14
- Filling around the pipe	14
- Compression	14
- Filling the excavation	14

7. Installation - building

Suspension	15
- Expansion	15
- Distance between supports	15
- Placing of supports	15
Longitudinal expansion	16
Precautions against the spreading of fire	17
Wall and storey penetrations	17
Pipe Layout	18
- Changes in direction	18
- Connections	19-20
Joint clamps	21
Projections on the socket end	22
Socket plug clamps/access plugs	22
Testing/leakage test	23

8. Handling

Transport and handling	24
Storage	24

9. Sound

BLÜCHER® drainage systems and sound	25
Legislation	25
Sound from drainage systems	25
Sound levels measurements	26
Sound reduction	26

10. Standards/approvals/labelling

EN1124	27
Type approvals	27
Labelling of products	27

11. Equipotential bonding

Example of equipotential bonding	28
----------------------------------	----

12. Quality assurance

ISO 9001	29
External quality assurance	29
Internal quality assurance	29

This brochure provides an overview of the most important technical considerations to be made in connection with planning, installation and maintenance of a drainage pipework system.

Please do not hesitate to contact us if you have any questions.

BLÜCHER, founded in Denmark in 1965, specialises in the manufacture of stainless steel drainage products.

Today, BLÜCHER is an international company with head offices and two production facilities in Denmark (Vildbjerg and Vojens) and subsidiaries in Norway, Sweden, the UK, Germany and France.

Throughout the rest of the world, BLÜCHER is represented by an extensive distributor network.

BLÜCHER® stainless steel drainage products are used for housing, commercial, industrial and marine drainage applications. BLÜCHER markets a very extensive range of standard products and in addition, customised items are also available to ensure that any drainage requirement can be satisfied.

The BLÜCHER® product range comprises pipes and pipe fittings for drainage

systems, domestic and industrial drain systems and channels for linear drainage solutions. All BLÜCHER® products are made entirely from stainless steel or acid-resistant stainless steel. All products are chemically descaled and passivated in order to enhance the natural corrosion resistance and provide a uniform matt silver surface finish.

The BLÜCHER® products are manufactured using the most modern production methods and state-of-the-art laser cutting and welding equipment. All products are manufactured to meet the most stringent requirements to corrosion, hygiene and fire safety rendering them equally suitable for new building and renovation of e.g. multi-storey residential buildings and industrial buildings.

Among our primary customer groups are housing associations, consultant engineers, plumbers, hospitals, shipyards,

companies in the food industry and the pharmaceutical industry. The emphasis placed on product development reflects BLÜCHER's commitment to deliver drainage systems suitable for today's construction methods. The most respected approval authorities endorse BLÜCHER® products worldwide, and BLÜCHER plays an important part as a working group member under the CEN international approval committee.

Outstanding quality has always been the leading principle of BLÜCHER's product development, and in 1991, BLÜCHER was one of the first companies in Denmark to be awarded an ISO 9001 certification. All BLÜCHER® products are manufactured under this internationally recognised quality assurance system.

Please do not hesitate to contact us for further information about the BLÜCHER® product range.

Product range

- BLÜCHER® EuroPipe drainage pipework system
- BLÜCHER® Drain floor drains
- BLÜCHER® Channel linear drainage
- Roof drains
- Soil pipework
- Sanitary articles

The product groups are inter-combinable modular systems providing a solution to any drainage project - entirely in stainless steel.

General advantages

The BLÜCHER® stainless steel drainage products offer numerous advantages:

- Ease and speed of installation
- Extensive standard product range
- Special articles available on request
- Hygienic, easy to clean
- Reliable
- Thoroughly tested high-quality products
- Capacity to supply
- Made in Denmark
- Customer-specific complete drainage installations
- ISO 9001 certification

The most reliable and easy-to-use drainage pipework system on the market!



The BLÜCHER® EuroPipe drainage pipework system consists of pipes and fittings in stainless steel grades AISI 304 and 316L with socket and lip sealing ring. Available in 40, 50, 75, 82, 110, 125, 160, 200, 250 and 315 mm pipe diameter sizes and in standard lengths from 0,15 to 6 metres BLÜCHER® EuroPipe is a versatile, lightweight and easy-to-install pipework system.

The extensive range of fittings is suitable for all applications from simple below-ground installations to complex industrial pipe systems.

Among the numerous advantages of the BLÜCHER® EuroPipe drainage pipework system are corrosion resistance, low weight, excellent hygienic properties, temperature resistance and fire resistance.

The up-to-date design of the BLÜCHER® EuroPipe pipework system and the BLÜCHER® pipe cutters (manual or electrical) also provide a better working environment. Due to the low weight and easy handling, installation is significantly faster compared to other metal pipework systems, and no heavy lifting is required.

DIMENSIONAL DRAWING, SOCKET AND SPIGOT END

PIPES AND FITTINGS

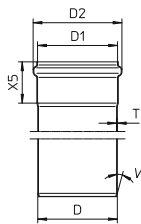

Type no.	EAN no.	D	D1	D2	X5	T	V (°)
811.XXX.040		40	41	52	41	1	20
811.XXX.050		50	51	61	42	1	20
811.XXX.075		75	76	87	50	1	20
811.XXX.082		82	83	94	52	1	20
811.XXX.110		110	111	123	57	1	20
811.XXX.125		125	126	140	60	1	20
811.XXX.160		160	161	177	72	1.25	20
811.XXX.200		200	201	219	90	1.5	20
811.XXX.250		250	251	277	108	1.5	20
811.XXX.315		315	316	344	116	2	20

■ MATERIAL PROPERTIES - STAINLESS STEEL

What is stainless steel?

The designation "stainless steel" covers a wide range of alloys with different properties.

One property common to all stainless steels is that they contain at least 12% chromium.

The stainless steels can be divided into three main groups and a few mixed types according to the structure of the steel.

The main groups are:

- Austenitic stainless steel
- Ferritic stainless steel
- Martensitic stainless steel

Of the three main groups, austenitic stainless steel is the most important, representing approx. 90% of total stainless steel consumption. Austenitic steel is also the only stainless steel suitable for drainage installations, and it is, of course, the type used by BLÜCHER.

Importance of alloying elements

Austenitic stainless steel contains at least 18% chromium and 8% nickel – thus the well-known designation "18/8" steel. Corrosion resistance generally increases with increasing content of chromium. In alloys with 12-13% chromium, the passive layer is strong enough to prevent the steel from corroding in normal or mildly aggressive media. The main effect of the alloying element nickel is on the structure of the steel and its mechanical properties. The steel's structure is austenitic with an adequate content of nickel. In contrast to the pure chromium steels (ferritic stainless steel), this results in significant changes in the mechanical properties, such as increased workability and ductility, better resistance to thermal stress and improved weldability. The austenitic structure also results in a change in the physical properties of the steel. For example, the steel is not magnetic. Nickel also increases resistance to corrosion caused by certain media.

Material specifications:

AISI - American standard

EN standard	1.4301	1.4404
SIS - Swedish standard	2333	2348

Material analysis:

Carbon (C%)	Max. 0,07	Max. 0,03
Chromium (Cr%)	17-19	16,5-18,5
Nickel (Ni%)	8,5-10,5	10-13
Molybdenum (Mo%)	-	2 - 2,5
Manganese (Mn%)	Max. 2	Max. 2
Silicon (Si%)Max. 1	Max. 1	Max. 1
Sulphur (S%)	Max. 0,03	Max. 0,03

Physical properties:

Structure		
Specific gravity (g/cm ³)	7.9	7.98
Melting point (°C)	Aprox.1400	Aprox.1400
Exfoliation temperature in air (°C)	800-860	800-860
Coefficient of expansion, 20 - 100°C (m/m · °C)	17,0 · 10 ⁻⁶	16,6 · 10 ⁻⁶
Specific resistance, 20°C (ohm · mm ² /m)	0.73	0.75
Thermal conductivity 20°C (W/°C · m) ¹⁵	15	15
Specific heat (J/g · K)	0.5	0.5

Mechanical properties:

Yield point R _{0,2} (N/mm ²)	195	190
Ultimate stress R _m (N/mm ²)	500-700	490-690
Hardness in Brinell HB (N/mm ²)	130-180	120-180
Elasticity E(20°C) (N/mm ²)	2,0 · 10 ⁵	2,0 · 10 ⁵
Elongation after fracture (A ₅ %)	min.45	min.45

Molybdenum has the same effect on the structure as chromium, but it also has a strongly positive influence on corrosion resistance. Molybdenum-containing steel is normally designated "acid-resistant" because of the resistance of these steels to certain types of acids. But acid-resistant stainless steel will also have limited resistance to some media such as chlorine-containing media (see table of resistances on p. 7).

Why is steel "stainless"?

The addition of chromium to the steel results in the building up of a passivating oxide film with a high content of chromium oxides. This oxide film protects the surface of the steel against oxygen in air and water.

An outstanding property of stainless steel is that the chromium oxide film automatically regenerates if the surface of the steel is exposed. This restitution of the oxide film can only occur if the surface of the steel is completely clean and free of tempering agents and slag from welding processes and residues from tools made from ordinary carbon steel.

If this surface contamination is not removed, the steel may ultimately corrode. To prevent this, the steel surfaces should be cleaned after welding and processing, e.g. by means of so-called acid pickling of the stainless steel.

The pickling effectively removes all impurities from the surface of the steel and permits the reestablishment of a strong, uniform chromium oxide film. The pickling bath normally consists of 0.5-5% v/v HF (hydrofluoric acid) and 8-20% v/v HNO₃ (nitric acid) at a temperature of 25-60°C. This acid bath removes residues, the existing chromium oxide film and traces of iron, leaving the clean steel surface. The restitution of a strong chromium oxide film starts in the subsequent rinsing in water.

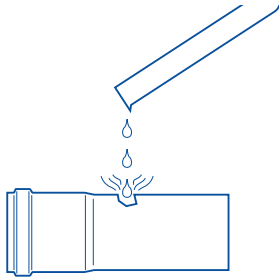

Corrosion resistance

The austenitic chromium-nickel steel used by BLÜCHER is the best of the stainless steel types in terms of corrosion resistance. This steel is resistant to many different chemical products and most cleaning agents. BLÜCHER® drainage products are therefore used for a wide range of applications, among others in the food industry, shipyards, the pharmaceutical industry, in breweries and dairies, in catering centres and in institutions.

When increased acid resistance is required and there is a risk of pitting and crevice corrosion, molybdenum-chromium-nickel steel can be used.

This acid-resistant stainless steel is, however, only partially resistant to chlorine-containing media and some other media.



Fire resistance

Stainless steel cannot burn and it is therefore classified as non-combustible.

This means that stainless steel pipes and drains can penetrate storey partitions without requiring additional fire insulation.

No hazardous substances are liberated from stainless steel in the event of fire.



Environment

Environmentally friendly manufacture, long life and 100% recyclability – BLÜCHER® drainage products are part of the ecological cycle.



Protection against blockages

The smooth surface of stainless steel and its accompanying excellent water-repellent properties are a major advantage in this situation:

- rapid discharge of water
- prevention of deposits

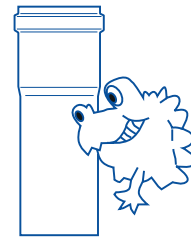

Hygiene

Experience from hygienic installations in the food industry, waterworks, catering centres and hospitals show that bacterial growth on stainless steel is significantly less than on, for example, plastic and ordinary steel surfaces.

This also applies to the BLÜCHER® drainage products. An unused piece of stainless steel pipe has a very low surface roughness (approx. $k = 0.0015$ mm).

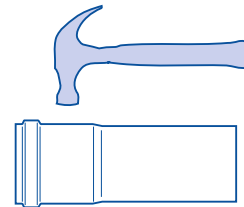

Resistance to deformation

Resistance to deformation, that is the ability of the steel to resist impacts, is outstanding for austenitic stainless steel at all temperatures. This is also the case at temperatures substantially below zero. Powerful impacts may result in denting in certain cases, but the steel cannot be actually damaged without great difficulty.

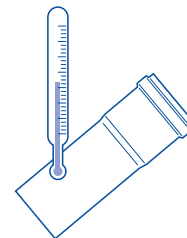

Resistance to thermal stress

Because of their low coefficient of expansion, stainless steel drainage products retain their shape perfectly at all normal temperatures in drainage installations.

Stainless steel drainage products also do not have to be stored or installed at certain temperatures. The steel is not affected by neither heat nor cold.

In installations where there is no possibility of expansion, attention is drawn to the longitudinal expansion (see table, p. 16).

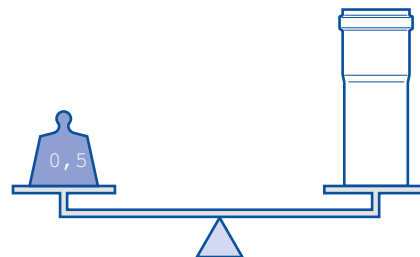

Weight

Stainless steel is strong relative to its weight.

BLÜCHER® drainage products are all made from thin-walled sheet metal, which efficiently utilises the inherent strength of stainless steel while making the products easy to handle and install.

■ ENHANCED FINISH

Usually, BLÜCHER® EuroPipe stainless steel drainage pipes do not require any finishing treatment as this high-quality material complies with most requirements with regard to surface finish and maintenance. If an enhanced surface finish is nevertheless desired, e.g. if the pipes are to be painted, a good adhesion must be ensured to obtain an aesthetically pleasing result. This can be done as follows:

Prior conditions:

- The surface must be smooth, even and without any dents.
- The surface must be free from scratches and marks.

Example of finishing treatment

- 1) Degrease pipes and fittings to a pure oil- and grease-free surface. For instance, an ammonium cleaning agent or suitable basic cleaner may be used.
- 2) After degreasing, dry and rinse pipes and fittings with pure water.
- 3) When the surfaces have dried, sand pipes and fittings to a rough surface with sand paper no. 180.
- 4) After sanding, apply two undercoats of acrylic paint to provide a base coat to which the subsequent painting adheres well.
- 5) Finally, paint the pipes twice with an acrylic enamel (see type designation) suitable for outdoor use (moisture resistant).

See also the paint manufacturer's guidelines.

TECHNOLOGY - Chemical resistance table

The table is based on laboratory experiments with chemically pure substances. The values should therefore be regarded as for guidance only.

	AISI 316 L Stainless	AISI 304 Stainless	Cast iron	Polyethylene	PVC	Polypropylene	EPDM	NBR	FPM
A = Very good service to operating limit of material									
B = Moderate service									
C = Limited or variable service									
D = Unsatisfactory									
Acetone	A	A	A	D	D	B	A	D	D
Acetic acid (dilute.) 30%	A	A	A	C	C	A	A	B	B
Acetic acid 100%	A	A	A	D	D	C	A	C	C
Acetic acid anhydride	A	A	A	B	D	C	B	C	D
Aluminium chloride	D	D	B	A	A	A	A	A	A
Aluminium sulfate	A	D	B	A	A	A	A	A	A
Ammonium carbonate	A	A	B	A	A	A	A	D	-
Ammonium chloride	B	C	B	A	A	A	A	A	-
Ammonium hydroxide	A	A	B	A	A	A	A	D	B
Amyl chloride	A	A	B	D	D	D	-	-	-
Anilin	A	A	B	D	D	B	B	D	C
Anilin hydrochloride	D	D	B	B	D	D	B	B	B
Barium chloride	B	B	B	A	A	A	A	A	A
Barium hydroxide	A	A	B	A	A	A	A	A	A
Benzaldehyde	A	A	B	D	D	C	A	D	D
Benzene	A	A	A	D	D	D	D	D	A
Benzoic acid	A	A	B	A	A	B	-	-	A
Borax	A	A	B	A	A	A	A	B	A
Boric acid	A	A	B	A	A	A	A	A	A
Bromine	D	D	D	D	D	D	-	-	A
Bromine chloride acid	D	D	D	A	D	C	A	B	A
Bromine hydrogen acid	D	D	D	A	A	C	A	D	A
Bromoethylene	A	A	B	D	D	D	-	-	-
Butanol	A	A	A	D	D	D	D	A	A
Butyl acetat	A	A	B	D	D	D	B	-	D
Butyric acid	A	A	A	D	D	A	-	-	-
Calcium bisulfate el sulfite	A	A	D	A	A	A	D	A	A
Calcium chloride	B	B	B	A	A	A	A	A	A
Calcium hydroxide	A	A	C	A	A	A	A	A	A
Calcium hypoklorite	B	C	B	A	C	B	A	C	A
Carbon disulfide	A	A	A	D	D	D	-	-	-
Carbon tetrachloride	A	A	A	D	D	D	D	C	A
Chloracetic acid (Mono)	D	D	B	D	D	D	B	-	-
Chloride	D	D	B	C	A	D	-	-	-
Chlorid acid	D	D	B	C	A	D	-	-	-
Chlorine (dry)	A	A	B	D	D	D	-	-	A
Chlorobenzene	A	A	B	D	D	D	D	D	A
Chloroform	B	B	B	D	D	D	D	D	A
Chlorosulfonic acid	B	C	A	D	D	D	D	D	C
Copper chloride	B	B	B	A	A	B	A	A	A
Copper nitrate	A	A	A	A	A	B	-	-	-
Copper sulfate	A	A	A	A	A	B	A	A	A
Ether	A	A	A	D	D	D	-	-	-
Ethyl chloride	A	A	A	D	D	D	A	A	A
Fatty acid	A	A	A	D	A	B	D	B	A
Flouiner (dry)	A	A	D	D	B	D	-	-	-
Flourine hydrogen acid	D	D	D	B	C	C	B	D	A
Formaldehyde	A	A	A	A	A	B	A	B	A
Formic acid	A	A	A	C	D	B	A	B	C
Furfural	A	A	B	D	D	D	B	D	D
Gallic acid	A	A	A	A	A	A	B	B	A
Hydrochloric acid	D	D	D	A	A	A	A	D	A
Hydrogen peroxide	A	A	B	C	D	C	C	D	B
Iodine (wet)	D	D	D	D	D	C	-	-	-
Lead acetate	A	A	B	A	A	A	A	B	-

NOTE: Concentration levels and length of exposure have a direct influence on the resistance of stainless steel to certain chemicals. Each application should therefore be carefully reviewed to determine the suitability of stainless steel.

Assumptions:

Data represented is to be used as a guide only, for detailed information please contact our technical department.

References:

- Corrosion Data Survey, 1969 Edition, Nace
- Corrosion Data Survey, 1975, Nace
- Corrosion Tables, Stainless Steels, 1979, Jernkontoret
- Chemical Resistance of Plastic Piping Materials, Cabot Corporation, 1979

	AISI 316 L Stainless	AISI 304 Stainless	Cast iron	Polyethylene	PVC	Polypropylene	EPDM	NBR	FPM
A = Very good service to operating limit of material									
B = Moderate service									
C = Limited or variable service									
D = Unsatisfactory									
Magnesium chloride	B	B	B	A	A	A	A	A	A
Magnesium sulfate	A	A	A	A	A	A	A	A	A
Mercury	A	A	A	A	A	A	A	A	A
Methanol	A	A	A	A	A	B	A	A	C
Methyl chloride	A	A	A	D	D	D	C	D	A
Methylene chloride	B	B	A	D	D	D	D	D	B
Natphalene	A	A	B	D	A	C	D	D	A
Nickel chloride	B	B	B	A	A	A	A	A	A
Nickel sulfate	A	A	B	A	A	A	A	A	A
Nitric acid	C	C	A	D	D	D	C	D	A
Oxalic acid	C	C	B	A	A	C	A	B	A
Perchloric acid	D	D	A	A	D	C	B	-	A
Phosphor acid	A	A	B	A	A	B	B	D	A
Picric acid	A	A	B	C	D	D	B	B	A
Potassium bromide	A	A	B	A	A	A	-	-	-
Potassium carbonate	A	A	B	A	A	A	-	-	-
Potassium chlorate	A	A	B	A	A	A	-	-	-
Potassium cyanide	A	A	B	A	A	A	A	A	A
Potassium hydroxide	A	A	D	A	A	A	A	B	B
Potassium nitrate	A	A	A	A	A	A	A	A	A
Potassium permanganate	A	A	B	B	B	C	-	-	-
Potassium sulfate	A	A	A	A	A	A	A	A	A
Potassium sulfide	A	A	A	A	A	A	-	-	-
Potassiumchloride	B	B	A	A	A	A	A	A	A
Propylene dichloride	A	A	A	D	D	D	-	-	-
Sal ammoniac	B	C	B	A	A	A	A	A	-
Silver nitrate	A	A	A	A	A	A	A	B	A
Soda (ash)	A	A	B	A	A	A	-	-	-
Sodium acetate	A	A	B	A	A	A	A	B	D
Sodium bicarbonate	A	A	A	A	A	A	A	A	A
Sodium bisulfate	A	C	A	A	A	A	-	-	-
Sodium bisulfite	A	A	D	A	A	A	A	A	A
Sodium bromide	B	B	B	A	A	A	-	-	-
Sodium chlorate	A	A	A	A	C	A	-	-	-
Sodium chloride	D	D	B	C	A	D	-	-	-
Sodium cyanide	A	A	A	A	A	A	A	A	A
Sodium fluoride	A	A	D	A	A	A	-	-	-
Sodium hydroxide	A	A	D	A	A	A	A	B	B
Sodium hypoklorite	D	D	B	C	A	B	B	B	A
Sodium nitrate	A	A	A	A	A	A	A	B	-
Sodium sulfate	A	A	A	A	A	A	A	A	A
Sodium sulfide	A	A	B	A	A	A	-	-	-
Sodium sulfite	A	A	D	A	A	A	-	-	-
Stannic chloride	B	C	B	A	A	A	B	A	A
Sulfur	A	A	A	C	A	B	A	D	A
Sulfur chloride	A	A	A	D	D	D	D	C	A
Sulfur dioxide	A	B	D	C	D	C	A	D	A
Sulfuric acid	D	D	A	D	D	C	B	D	A
Sulfurous acid	A	C	D	A	A	C	B	B	A
Tionyl chloride	A	A	B	D	D	C	D	-	A
Toluene (toluol)	A	A	A	D	D	D	D	D	A
Trichloroethylene	A	A	A	D	D	D	D	C	A
Turpentine	A	A	B	D	D	D	D	A	A
Xylene (xylol)	A	A	B	D	D	D	-	-	-
Zinc sulfate	A	A	A	A	A	A	-	-	-

■ PUSH-FIT SOCKET JOINT

Lip sealing rings

The sealant between socket and spigot end is designed as a lip sealing ring.

The lip seal ensures quick and efficient installation of the pipe system while also providing a tight seal both under pressure and with a vacuum.

BLÜCHER's lip sealing ring is available in three different rubber qualities.

EPDM: This sealing ring is black and made of ethylene propene rubber. This is BLÜCHER's standard sealing ring and it is suitable for all rainwater and waste water installations where there is no oil or no petrol residues in the waste water.
The EPDM lip seal is a good all-round rubber quality suitable for a wide range of applications.

NBR: This sealing ring is black with a yellow spot and made from nitrile rubber and is the sealing ring to be used where there are petrol or oil residues on the waste water (e.g. in association with oil and petrol separators at service stations, garages etc.).
The NBR lip seal should not be used where there is a risk of temperatures above 80°C. NBR is not resistant to solvents.

FPM: This sealing ring is lilac and made from fluorine rubber (Viton). This is BLÜCHER's sealing ring for special applications. The material is particularly heat-resistant and resistant to oil, solvents and strong acids. However, the FPM seal has only limited resistance to e.g. butyl acetate, acetone and methyl alcohol.

For advice regarding the suitability of the different rubber qualities, consult BLÜCHER.

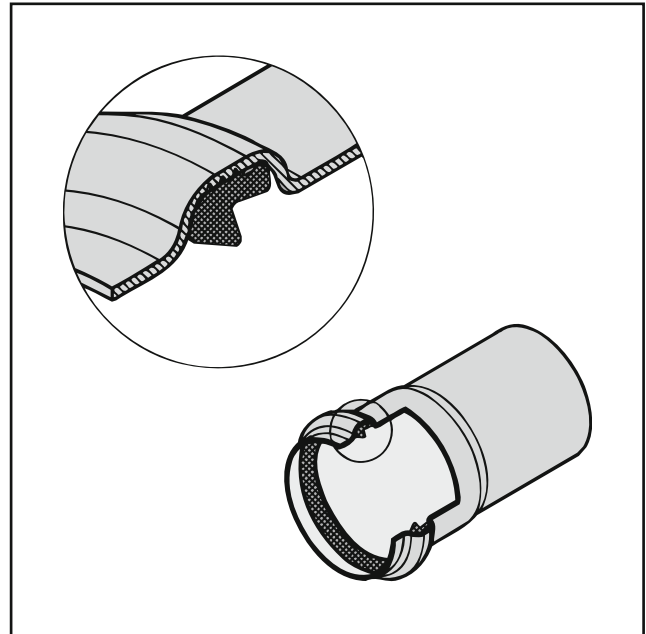

Rubber types

International designation	EPDM	NBR	FPM
Rubber type	Ethylene propene	Nitrile	Viton
Nominal hardness IRHD	55 (+/-5)	53 (+/-5)	70 (+/-5)
Colour	Black	Black/yellow	Green
Tensile strength MPa	14,0	14,0	8,0
Elongation after fracture %	500	500	200
Max. temperatur range	-40/+100	-30/+80	-25/+200

Resistance

Wearability	3	2	2
Resistance to mineral oil	3	1	1
Resistance to vegetable oil	2	1	1
Resistance to benzene/petrol	4	1	1
Resistance to common diluted acids and bases	1	2	1
Resistance to ozone and weather stresses	1	3	1

1 = good - 2 = medium - 3 = limited - 4 = poor

■ MAINTENANCE OF A DRAINAGE PIPEWORK INSTALLATION

All drainage installations require some maintenance, and it is a professional duty of the plumber/sewerage contractor to provide the user with the necessary guidelines for use, operation and maintenance of drainage installations. Far too often, the user has to discover on his own how to use and maintain the drainage installation. The experience gained this way can be very costly for both the user and others, especially for society.

Printed instructions for use are suitable for advising the user of substances which should not be discharged through a drainage installation.

Such instructions could for example include the following items:

- waste water containing substances that may cause deposits of sludge or solids such as sand, plaster or iron shavings which may cause damage to the drainage pipes, the waste water treatment plant or the recipient
- waste water with substances which might be inflammable or explosive, rendering water treatment dangerous
- waste water at temperatures exceeding the limit temperature of the pipes, the waste-water treatment plant or the recipient
- waste water containing substances, e.g. toxins, which may

cause damage to the drainage pipes, the waste water treatment plant or the recipient

- waste water containing fats and oils, e.g. frying oils
- waste water containing objects that might cause blockages. General information about what may be flushed down the toilet is particularly important. Sanitary napkins, paper nappies, cotton buds and cloths flushed down the toilet are a very common cause of blockages. A properly placed waste bin with a label clearly indicating what to dispose of in the waste bin and not in the toilet can prevent many problems.

Maintenance - generally

Maintenance comprises both preventive maintenance and remedy of operational problems detected. Preventive maintenance can avert operational problems in a drainage installation. Below are a number of examples of how to maintain a drainage installation:

■ PREVENTIVE MAINTENANCE

Floor drains

Floor drains with side inlets from showers and hand basins under the top grating are particularly likely to become blocked by hair etc. The drain should be cleaned regularly, including removal and thorough cleaning of the water trap.

Water traps

Water traps through which only small quantities of water containing relatively many solids are discharged, are likely to become blocked. A thorough flushing of the drain through the water trap with a large quantity of water should take place regularly. This problem is particularly likely to occur in connection with bottle water traps in drains from hand basins in separate toilet rooms.

Ventilating pipes

Blockages of ventilating pipes are often caused by birds' nests in the pipe. If birds' nests are found they should be removed to avoid odours as vacuum will form in the water traps and also because excess pressure in the ducting system will be balanced through covers in places where the odour can be very inconvenient. Birds' nests can be avoided by covering the ventilating pipe opening with wire netting.

How to repair operating problems

Operating problems, especially blockages, may occur in any drainage installation and can often be repaired by cleaning the drain thoroughly. Recurrent blockages at the same location in a drainage installation should give rise to an investigation of the cause and repair if necessary.

Recurring blockages are usually caused by defects in the drainage installation, and most often they become apparent shortly after the system has been put into use. The defects may, for example, be insufficient falls, cavities in the pipes, poor joints or construction

waste admitted to the system during the completion of construction work either through the sanitary units or through open pipe ends. Consequently, branches should be kept closed during completion of construction work. The drainage system must also be thoroughly cleaned and flushed immediately after completion in order to ensure that any defects are discovered before the drainage system is put into use.

Another frequent cause of recurring blockages is fat discharged through vertical pipes connected to kitchen sinks. This is not to say that the kitchen sink is used incorrectly as hot fat is flushed through the water trap and, when cooling, deposits on the internal pipe walls. Usually, such blockages will only become apparent long after the system has been installed. Consideration should therefore be given to installing a grease separator, e.g. for catering centres, restaurants and institutions where it is to be expected that fats will be discharged into the pipework system.

Rodding access

An appropriately designed drainage system has a number of integrated rodding accesses through which the pipes can be cleaned. Furthermore, drain fittings, water traps and gratings of sanitary units can also be removed to provide access to the pipework system.

The pipework system itself in buildings should always contain integrated access pipes with removable covers and should always be fitted at adaptors to below-ground installations while the need for and the location of other access pipes depend on the design of the pipework system.

Maintenance of a BLÜCHER® EuroPipe installation

BLÜCHER's stainless steel drainage systems require only a minimum of maintenance. The smooth, acid-pickled surface of the pipe retains its uniform matt silver finish, and in most environments such as wet rooms, bathrooms and kitchens no maintenance of the pipework is required.

If the pipework system is used as exterior downpipes, it is recommended that the installation be cleaned one to four times each year.

In particularly demanding environments such as the food industry, laboratories, the chemical industry and agriculture, it may be necessary to clean the installation to avoid the formation of coatings which can cause subsequent corrosion. Cleaning can, for example, be done by high pressure flushing, both outside and inside.

It is recommended that in e.g. laboratories where aggressive substances/liquids are discharged regularly, the pipework should be flushed thoroughly with plenty of water regularly, even daily if required. The pipework can also be flushed/cleaned with various cleaning agents, but care should first be taken to ensure that the cleaning agent is suitable for stainless steel. Contact the manufacturer of the cleaning agent if in doubt.

Special attention should be paid to installations used by many different users, e.g. in chemistry laboratories in schools, where it can be difficult to control which substances/liquids are discharged through the sink. Particularly aggressive and hazardous substances should therefore be collected in containers and disposed of in another way - and not through the drainage system. Regular flushing with water is also part of the normal cleaning procedure in these applications.

N.B.!

Only substances to which stainless steel is resistant should be discharged into the BLÜCHER® EuroPipe system.

See table of resistance on page 7.

If there is a risk that aggressive substances have nevertheless been discharged, the system should be flushed with plenty of cold water. Contact BLÜCHER if in doubt as to whether the stainless steel is resistant to the liquids/substances in question.

Discolouration

Stainless steel can be discoloured by corrosion if exposed to a more aggressive environment than that for which it was designed, i.e.

- Highly polluted air: "industrial atmosphere"
- Salt solutions and hydrochloric acid
- Residual coatings from chlorine-containing cleaning agents
- Inappropriate design from the point of view of corrosion, i.e. designed with pockets or narrow crevices.

N.B.: The risk of corrosion is significantly reduced or eliminated entirely by choosing molybdenum stainless steel grade 316L.

- Transfer of iron residues under the influence of moisture
- Steel packaging bands
- Fork-lift trucks
- Steel shelves which have not been surface-treated
- Steel tools
- Transport rollers
- Securing elements etc.

N.B.: All made from ordinary carbon steel.

Choosing a higher grade of alloy does not prevent the transfer of iron residues.

It is not the stainless steel surface which corrodes, but particles from the carbon steel adhering to the surface of the stainless steel. Under the influence of moisture, the corrosion will already be evident after a few days if the surface is attacked.

Preventive arrangements

On delivery from the factory, all stainless steel surfaces have been passivated and are perfectly clean. In other words, the stainless steel has formed a corrosion-resistant oxide film over the entire surface.

To preserve the outstanding anti-corrosion properties of the stainless steel, especially if it is to be used outdoors, the following instructions should be followed with respect to design, manufacture and installation:

Choose the right material with respect to any impurities found in the surroundings such as soot, sulphur dioxide, salt water or road salt.

Choose the right design which will permit rainwater or rinsing water to remove all dust or dirt from the entire stainless steel surface.

Stainless steel grade AISI 316L should be specified for components which are not exposed to rainwater or to components to be installed in geographic areas where it rarely rains.

Use stainless steel brackets, screws, bolts and nuts in the installation.

ponents and carbon steel items in places where the materials are exposed to moisture or water (i.e., establish electrical insulation).

Use clean tools which have no adhering iron shavings or particles or rust.

Never use steel brushes and steel wool made from ordinary carbon steel. Only stainless steel wool or brushes will not attack the surface.

Do not use hydrochloric acid to remove cement mortar residues from stainless steel surfaces. Use water to remove the mortar before it dries.

Avoid the risk of galvanic corrosion between stainless steel com-

■ HOW TO REMOVE STAINS AND DISCOLOURATION FROM STAINLESS STEEL SURFACES

If the stains on or the discolouration of the stainless steel surface is so serious that it cannot be removed by ordinary rinsing with water, the following cleaning methods are recommended:

Problem	Cleaning agent and method
Fingerprints	Clean with spirit, thinner or acetone, rinse with cold water, wipe dry.
Oil and grease	Clean with an organic solvent of the above type, then wash with soapy water or a mild cleaning agent. Rinse with cold water, wipe dry.
Difficult stains and discolouration	Clean with a mildly abrasive cleaning agent and rub along the surface structure. Rinse with clean cold water and wipe dry. Or: wash with a 10% phosphoric acid solution. Rinse with an ammonium solution, then with clean cold water, wipe dry.
Label ink	Ink from manufacturer's labels can be removed with acetone or methyl ethyl ketone.
Plastic film	PVC film can adhere after a time. Use spirit to remove.
Tarnishings and more difficult stains	Wash with an abrasive cleaning agent or: rub with a Scotchbrite sponge along the surface structure; rinse with clean cold water and wipe dry.
Discolouration from corrosion	Wet the surface with a solution of oxalic acid and let the solution sit for 15-20 minutes. Rinse with clean cold water and wipe dry. If necessary, wash with an abrasive cleaning agent as described above.
Paint	Clean with paint remover (or use a soft nylon brush or sponge). Rinse with clean cold water and wipe dry.
Scratches on polished or brushed surfaces (polish). Polish along the surface structure, wash with soapy water, wipe dry.	Polish with a rotating polishing pad (always use an iron-free water or a mild cleaning agent, rinse with clean cold water, wipe dry). N.B.: this method cannot be used on smooth or rolled patterned surfaces without leaving visible traces.
Precautions Use only acids if other methods have proved inadequate. Follow the applicable safety provisions for such work and wear rubber gloves and protective goggles. Ensure proper ventilation.	

■ INSTALLATION GUIDE

1. Cutting

Use BLÜCHER® manual or electric pipe cutter to cut the pipes. The pipes can then be installed without subsequent finishing.

N.B! Fittings may not be cut.

2. Check of lip seal

Check that the lip sealing ring is correctly installed in the socket.

3. Cleaning

If necessary, clean lip seal and socket before jointing.

Apply lubricant.

4. Jointing

Joint the pipes with a slightly turning movement.

Electric pipe cutter



A detailed user guide is provided when buying or hiring an electric pipe cutter.

Manual pipe cutter

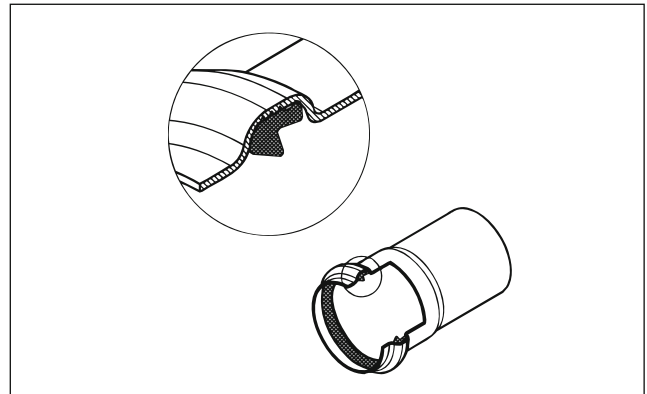
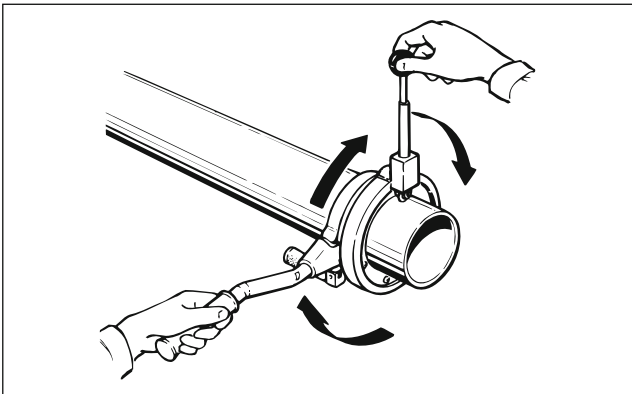

Jointing of socket and spigot end

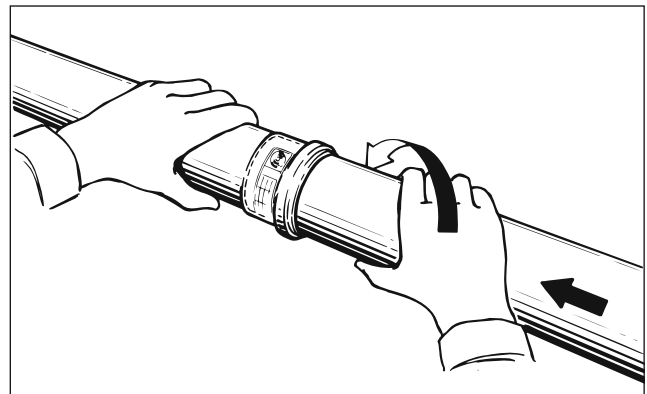
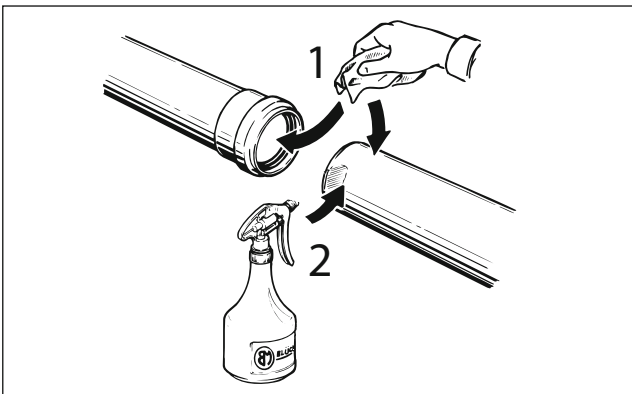

Insertion depth

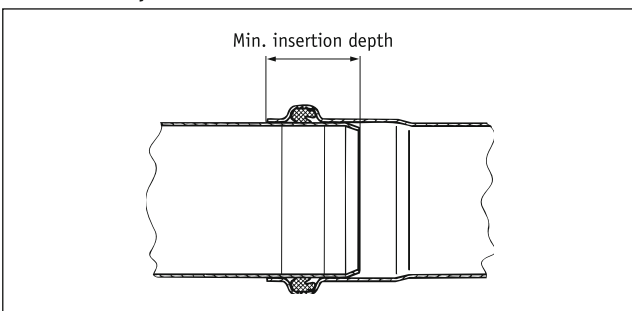

Pipe dimension in mm	Max. insertion depth from end of socket to spigot end	Min. insertion depth from end of socket to spigot end
ø 40 mm	47 mm	30 mm
ø 50 mm	47 mm	30 mm
ø 75 mm	55 mm	35 mm
ø 82 mm	57 mm	37 mm
ø110 mm	62 mm	40 mm
ø125 mm	65 mm	47 mm
ø160 mm	76 mm	50 mm
ø200 mm	98 mm	63 mm
ø250 mm	116 mm	70 mm
ø315 mm	126 mm	80 mm

■ VALUES FOR MINIMUM AND MAXIMUM SOIL COVERING

BLÜCHER EuroPipe min and max soil covering [m] according to DS 430

Conditions:



- Pipe above ground water level.
- Soil compressed to 93% (standard proctor)

	ø110		ø125		ø160		ø200		ø250		ø315		
	Normal	Heavy	Normal	Heavy	Normal	Heavy	Normal	Heavy	Normal	Heavy	Normal	Heavy	
Density [kN/m ²]	16	0,24	0,37	0,32	0,46	0,33	0,48	0,36	0,51	0,46	0,63	0,43	0,59
		57,92	57,91	51,51	51,49	50,42	50,40	48,60	48,58	21,81	21,77	24,37	24,33
	18	0,24	0,37	0,31	0,45	0,32	0,47	0,35	0,50	0,45	0,62	0,42	0,58
		51,48	51,47	45,78	45,76	44,81	44,79	43,19	43,17	19,38	19,33	21,65	21,61
	20	0,23	0,36	0,31	0,45	0,32	0,46	0,34	0,49	0,44	0,61	0,41	0,57
		46,33	46,31	41,20	41,18	40,33	40,31	38,87	38,85	17,43	17,38	19,48	19,43
	22	0,23	0,36	0,30	0,44	0,31	0,45	0,33	0,48	0,43	0,60	0,40	0,56
		42,12	42,10	37,45	37,43	36,66	36,64	35,33	35,31	15,84	15,79	17,70	17,66

Conditions:

- Pipe below ground water level. (water level = terrain)
- Soil compressed to 93% (standard proctor)
- $\gamma\text{-}\gamma = 8\text{ kN/m}^3$

	ø110		ø125		ø160		ø200		ø250		ø315		
	Normal	Heavy	Normal	Heavy	Normal	Heavy	Normal	Heavy	Normal	Heavy	Normal	Heavy	
Density [kN/m ²]	16	0,27	0,41	0,36	0,53	0,38	0,56	0,41	0,60	0,56	0,77	0,52	0,72
		35,18	35,16	30,93	30,89	30,22	30,19	29,07	29,04	13,81	13,74	15,55	15,49
	18	0,26	0,40	0,35	0,52	0,37	0,54	0,40	0,57	0,53	0,73	0,49	0,68
		33,78	33,75	29,80	29,77	29,14	29,11	28,05	28,02	13,07	13,01	14,71	14,65
	20	0,25	0,40	0,34	0,50	0,36	0,52	0,39	0,55	0,51	0,70	0,47	0,66
		32,15	32,12	28,42	28,39	27,80	27,77	26,77	26,74	12,33	12,26	13,86	13,80
	22	0,25	0,39	0,33	0,49	0,35	0,51	0,37	0,54	0,49	0,68	0,46	0,63
		30,49	30,47	26,99	26,97	26,41	26,38	25,44	25,41	11,62	11,56	13,06	13,00

-  Minimum soil covering
-  Maximum soil covering

Please note, that ø250mm and ø315mm calculations are based on "slacker pipes" according to DS 430

Where min. values are given in the tables for soil covering, also the frost-free depth must be taken into account.

■ BELOW-GROUND INSTALLATION

Filling around the pipe

Filling around the pipe can only start when the position of the pipe has been checked and approved.

Compression

The pipes may not be dislocated or damaged by the compression. Avoid tipping the filling directly onto the pipe.

If a machine is used for compression, the equipment's own weight and impact force must be adapted to conditions.

The filling should be compressed to at least 93%.

Filling the excavation

Soil from the excavation can be used for filling, but larger stones and blocks may not be used. Compression of the filling material outside reinforced areas is not necessary if the settling will not cause problems or damage.

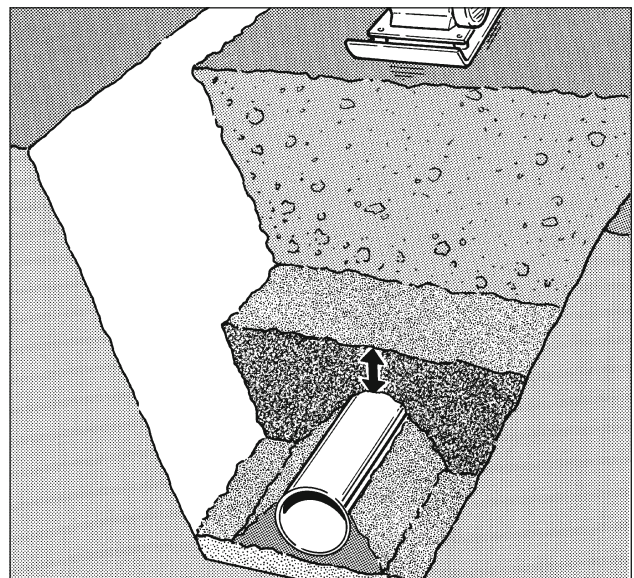
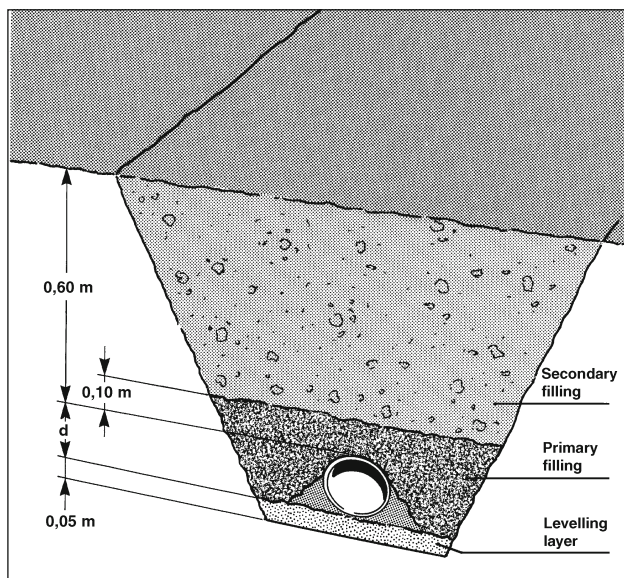
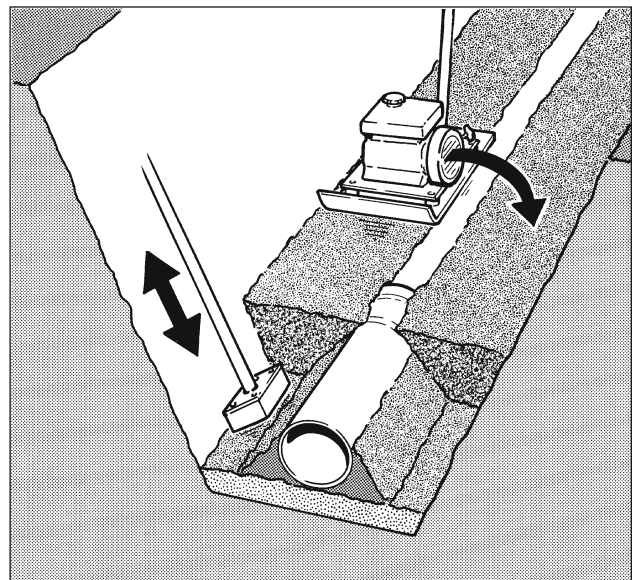
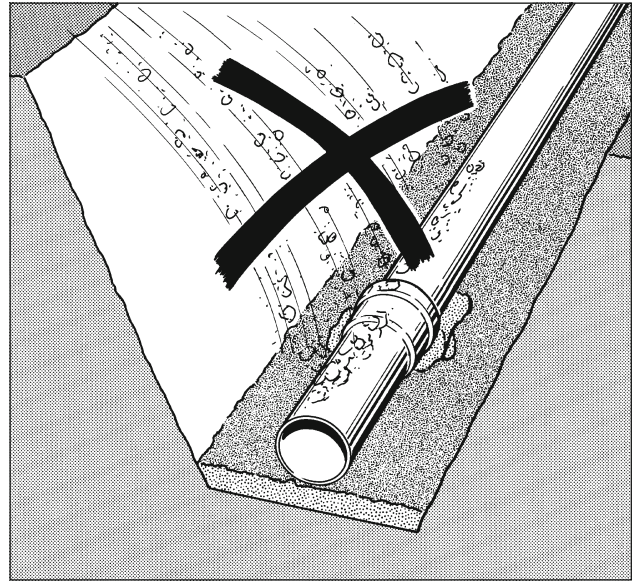

■ SUSPENSION OF DRAINAGE PIPES

The following section describes the fixing of pipes for vertical and horizontal pipe runs.

Vertical piping

One mounting per storey is normally sufficient, but the maximum gap between each mounting should be 3 m. Where larger inlets are connected, the downpipe must be secured immediately below the inlet.

Expansion

Both horizontal (suspended or ground) pipes and vertical runs must be mounted or fixed so that the force arising through heat expansion can neither bend the pipes nor pull the male ends from the sleeves. (See table p. 16).

- 1) The possibility of expansion must be ensured particularly where the installation is embedded or fixed at short intervals. (See table p. 16).

Horizontal runs

Dim.	Distance between supports*	Dim.	Distance between supports*
mm	m ¹⁾	mm	m ¹⁾
40	2,0	125	3,0
50	2,2	160	3,3
75	2,5	200	3,3
82	2,6	250	3,0
110	2,8	315	3,0

* The distance between the suspended fixing points must be calculated on the basis of a permissible 1 mm bending of the pipe. The bending for a single mounting is calculated for a water-filled pipe.

- 1) Applies to flat lengths of pipe. Where there are fittings in the suspended piping, the mounting points must be so placed that either the branch or the through pipe is held directly behind the sleeve. If this is not possible, the span must be reduced to half the quoted values or, as an alternative, safety clamps may be installed for stability.

THE PIPEWORK SYSTEM MUST BE PROPERLY SUPPORTED AND FIXED TO PREVENT THE SOCKET AND THE SPIGOT END FROM SLIDING APART UNDER ALL ANTICIPATED CONDITIONS.

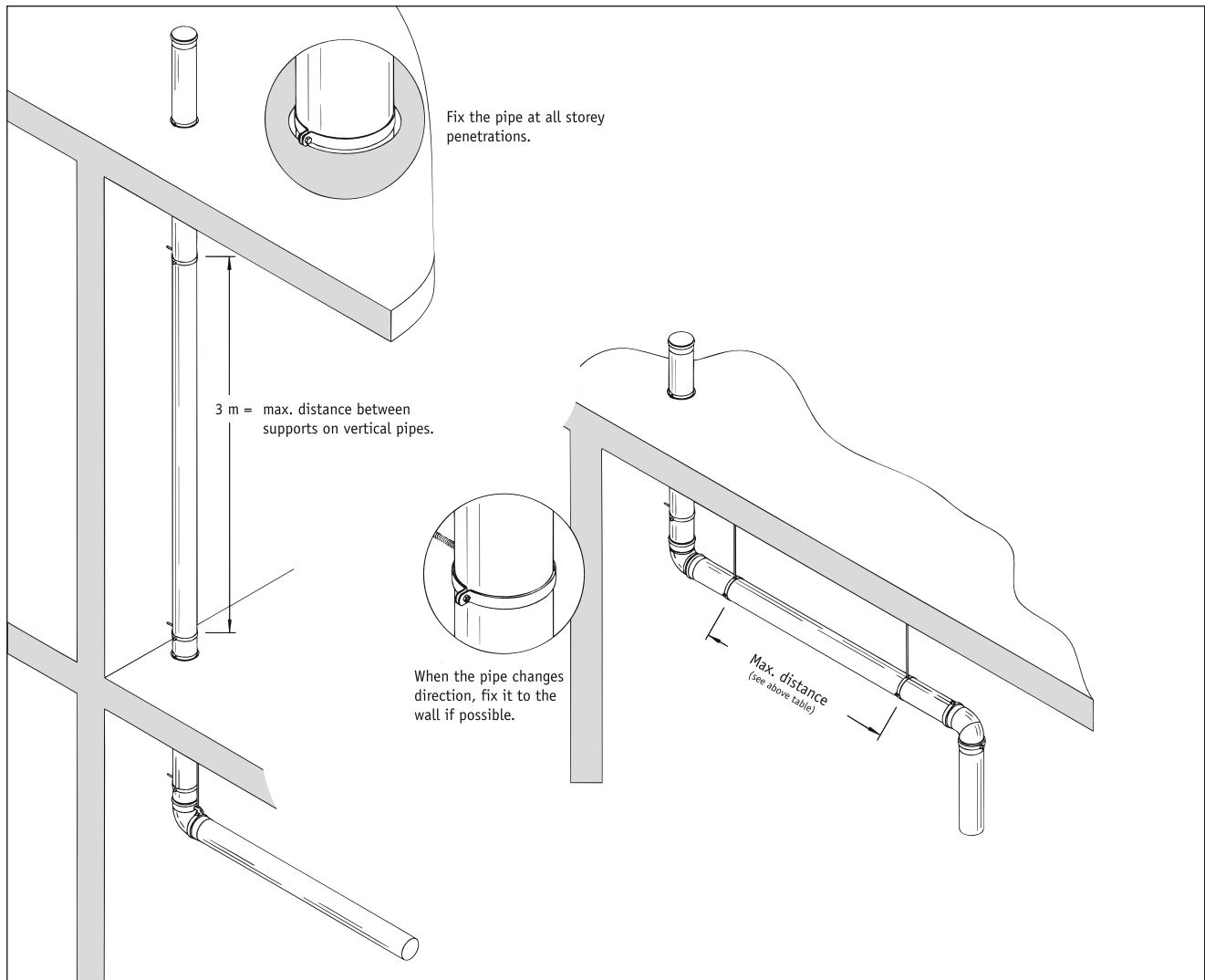

LONGITUDINAL EXPANSION

The figure to the right shows the relationship between pipe length L in m and longitudinal expansion Δl in mm for various temperature differences Δt .

Example: A 3 m pipe will expand by 2.5 mm at a temperature difference of 50°C.

The increase in length for a given pipe length can also be calculated from the following formula.

$$\Delta l = 0.0165 \times \Delta t \times L$$

where

Δl = longitudinal expansion in mm

0.0165 = coefficient of expansion in mm/m/°C

Δt = temperature difference in °C

(Δt = max. temp. in the pipe system
- temperature when pipe system installed)

L = length of the pipe system in m.

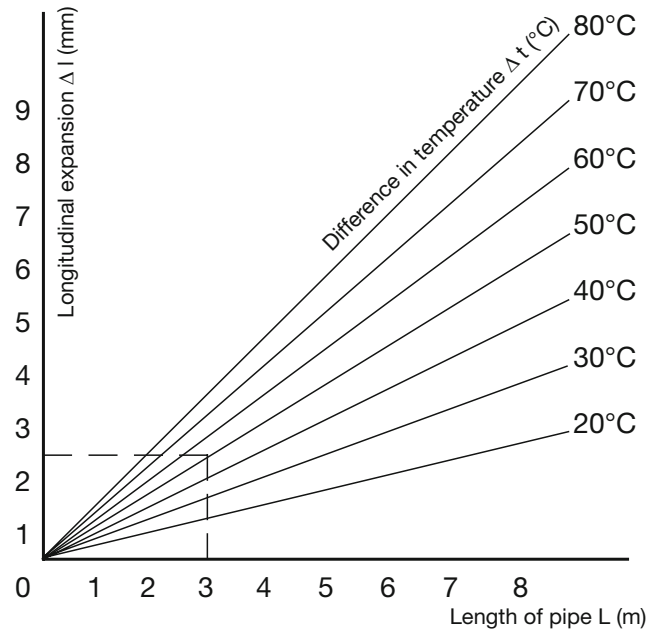

■ PRECAUTIONS AGAINST THE SPREADING OF FIRE/WALL AND STOREY PENETRATIONS

BLÜCHER® EuroPipe and fire

When installing pipework in buildings it must be ensured that fire prevention requirements are fulfilled.

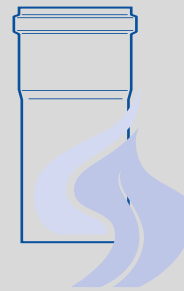

Fire resistance

Stainless steel cannot burn and it is therefore classified as noncombustible. This means that the BLÜCHER® EuroPipe drainage system can penetrate storey partitions in multistorey buildings without extra fire insulation. Current national regulations are of course always to be followed. No hazardous substances are liberated from the steel in the event of a fire.

Penetrations

Fig. 1-3 represent examples of how a BLÜCHER® EuroPipe can penetrate a wall or a storey partition.

A stainless steel drainage installation is considered non-combustible and consequently, a proper embedding as shown in Fig. 1 is sufficient for penetrations through walls and storey partitions of a fire compartment.

This solution can, however cause noise problems.

If the solution in Fig. 2, which is better in terms of noise, is chosen, it must be ensured that the pipe cannot move in the event of fire, e.g. by fixing it as shown in Fig. 3.

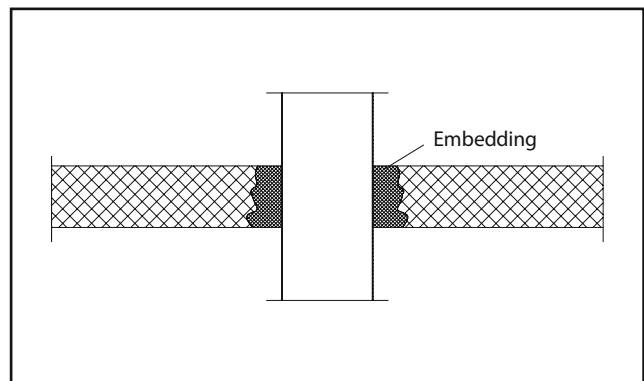

Fig. 1. Embedded non-combustible drainage pipe.

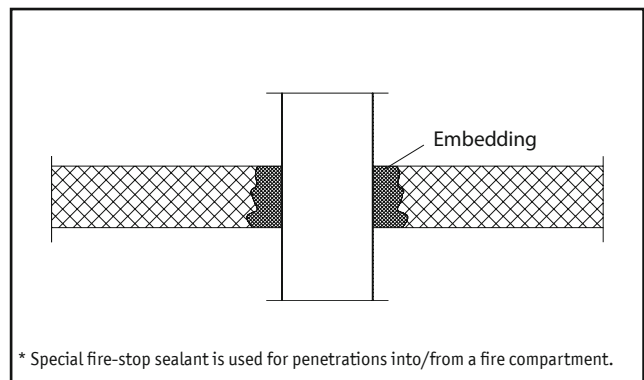

Fig. 2. Low-noise and fire-safe penetration of non-combustible drainage pipe.

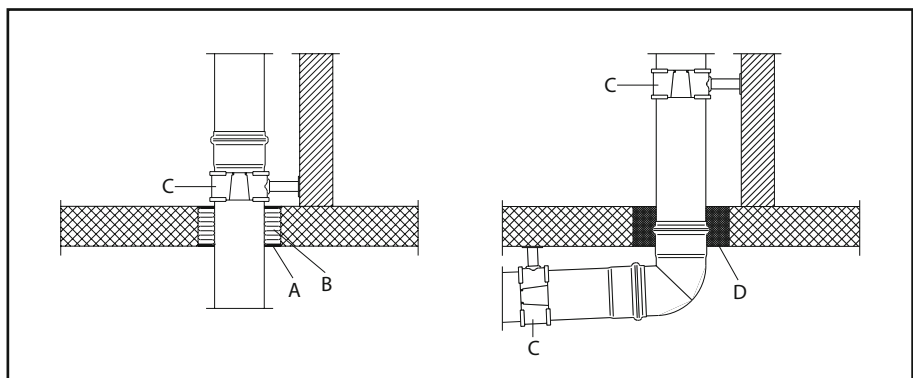

Fig. 3. Examples of fixing of non-combustible drainage pipes.
A: Sealant. B: Mineral wool. C: Pipe bracket. D: Embedding.

PIPE LAYOUT - CHANGES OF DIRECTION

Changes in direction in a BLÜCHER® EuroPipe drainage pipework system must be established with prefabricated fittings causing the least possible flow resistance.

Below are BLÜCHER's recommendations for changes of direction in pipework installation. Please note that under all circumstances are any local regulations to be observed.

Change of direction from vertical to horizontal

If a toilet is connected to the drainage pipework more than 10 m from the change of direction, no sanitary units should be connected closer than 1 m from the change of direction.

The change of direction can be effected with a short 87°-88° bend provided that:

- Sanitary units are connected to the vertical pipe at least 2 m over the change of direction and to the horizontal pipe at least 1 m from the change of direction.
- The drop from the uppermost water trap to the change of direction does not exceed 10 m.
- A maximum of 3 toilets is connected to the vertical pipe.

If these conditions cannot be fulfilled, the change in direction should be carried out by means of two 45° bends or a 87°-90° bend with a large radius or an approved duckfoot bend.

In buildings with more than 8 storeys above the bend, a straight pipe section of at least 0.3 m should be inserted between the bends.

Change in direction from horizontal to vertical

As shown in Fig. 2, the change in direction can be carried out by means of a short 87°-88° bend provided that:

- Sanitary units are connected to the horizontal pipe at least 1 m from the change in direction and to the vertical pipe at least 1 m from the change in direction.
- A maximum of 1 toilet is connected.

Changes of direction in horizontal lines

Fittings with a max. 87° change of direction (see Fig. 3) can be used in pipe runs to which only one sanitary unit is connected.

As sharp changes of direction increase the risk of blockages, special attention should be paid to pipe runs particularly exposed to blockages, e.g. pipes from toilets and kitchen sinks.

The larger the radius of the bend, the lower the risk of blockage. Consequently 87° bends with a short radius should only be used for changes in direction in connection pipes.

Bends with a maximum of 45° should be used in pipe lines to which more than one sanitary unit is connected.

For 90° changes in direction a straight pipe section of at least 0.3 m should be inserted between the two bends (see Fig. 4).

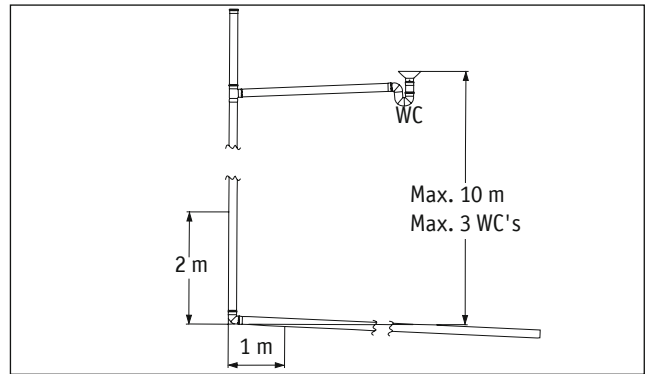

Fig. 1. Requirements for using a short 87°-88° bend for change from vertical to horizontal pipe run.

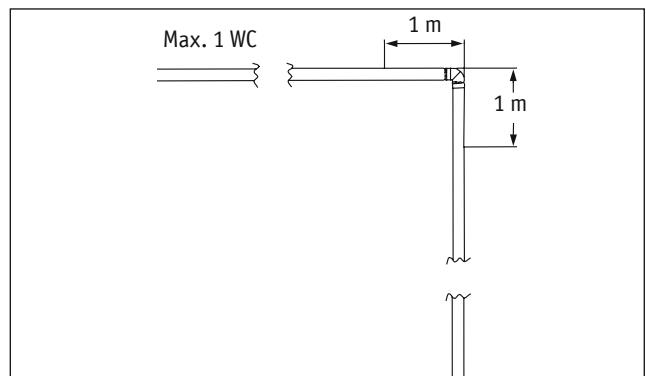

Fig. 2. Requirements for using a short 87°-88° bend for change from horizontal to vertical pipe run.

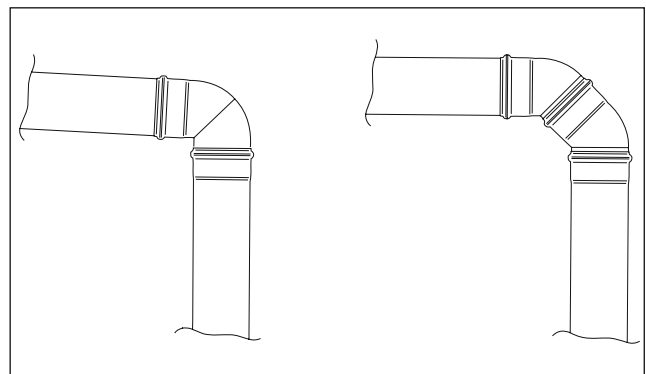

Fig. 3. 88° changes in direction can be used in pipe runs to which only one unit is connected.

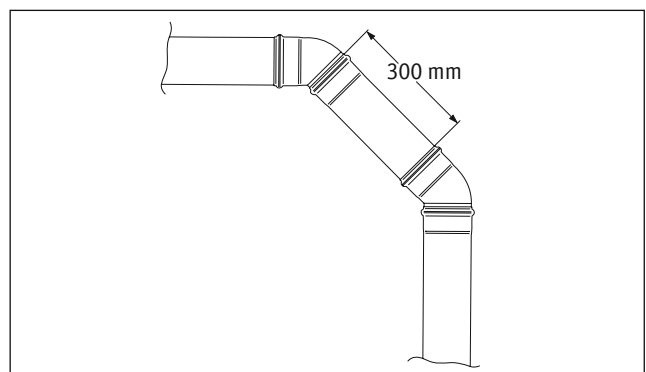

Fig. 4. Two 45° bends with a straight pipe section of at least 0.3 m between the bends should be used for 90° changes in direction.

PIPE LAYOUT - connections

Connection of drainage pipes - BLÜCHER® EuroPipe must be established in such a way that:

- no deposits occur which may lead to blockages
- no overflows can occur which may cause problems with and damage to sanitary units connected to the pipework system
- ventilation/pressure equalisation is within acceptable limits
- adequate access is provided

Connections to stacks

The vertical distance between the water surface of the water trap connected to a branch pipe and the bottom of the branch at the junction to the vertical pipe should be at least 100 mm (see Fig. 1). This will prevent overflows from the vertical pipe to the water trap.

Non-ventilated side pipes should be connected to a vertical pipe using 87°-88° branch pipes, and the side pipes should be installed with smallest possible fall (see Fig. 2).

The distance between two side pipes on the same stack should be at least 100 mm (see Fig. 3).

When using double branch pipes with connecting angles larger than 45°, no sanitary units should be connected to the side pipes closer than 700 mm from the vertical pipe (see Fig. 4).

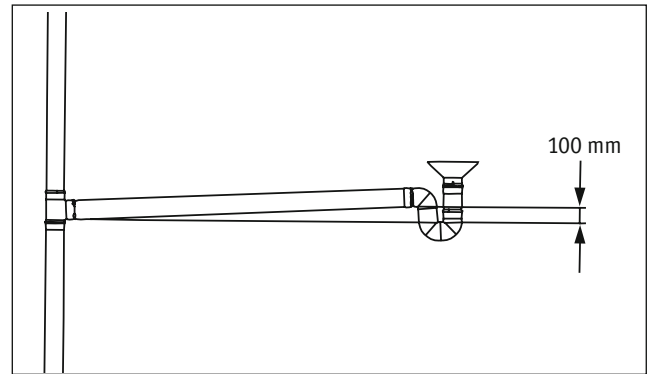

Fig. 1. The vertical distance between water surface in the water trap and bottom of the side pipe should be at least 100 mm.

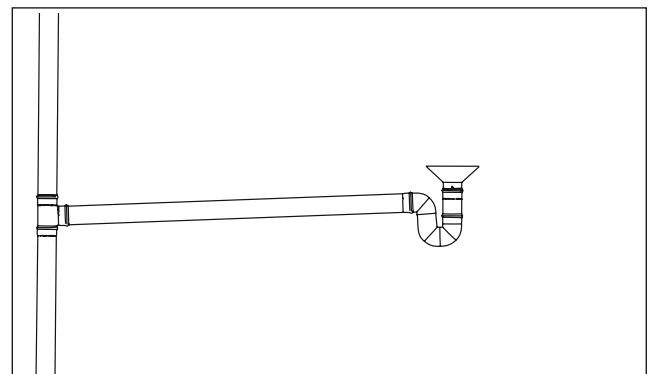

Fig. 2. Non-ventilated pipes should be connected to vertical pipes with 87°-88° branch pipes and the side pipe should have the smallest possible fall.

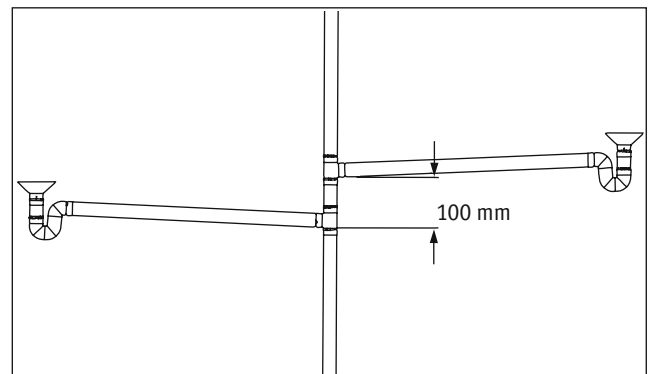

Fig. 3. The distance between two side pipes on the same stack should be at least 100 mm.

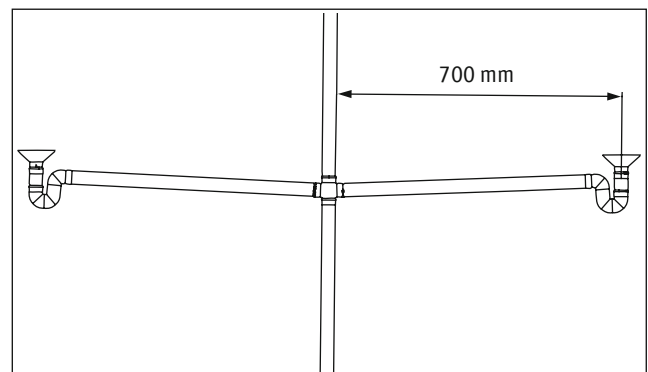

Fig. 4. When using double branch pipes with connecting angles larger than 45°, no sanitary units should be connected to the side pipes closer than 700 mm to the vertical pipe.

PIPE LAYOUT - connections

Branch pipes with a minimum connecting angle of 45° (see Fig. 5) can be used when connecting ventilated side pipes.

If toilets are connected more than 10 m above a change in direction from vertical to horizontal pipe run, sanitary units should be connected at least 1 m from the change in direction (see Fig. 6).

Connection to horizontal pipes

Connecting horizontal pipes to horizontal pipes
These connections are made mainly in cleaning and inspection wells or in manholes.

Double branch pipes are not suitable (see Fig. 7).

Connection of vertical pipes to horizontal pipes

If the height of fall from the water trap in the uppermost connected toilet is max. 9.5 m and max. three toilets are connected, the top connection can be a fitting with an angle of connection of max. 45° (see Fig. 8). If the fall of height or the loading is greater, junctions should be used, i.e. a straight horizontal pipe section of at least 0.3 m should be inserted between the vertical and the horizontal pipe (see Fig. 9).

Of these the side connection ensures the better flow, and it should be used as far as practically possible.

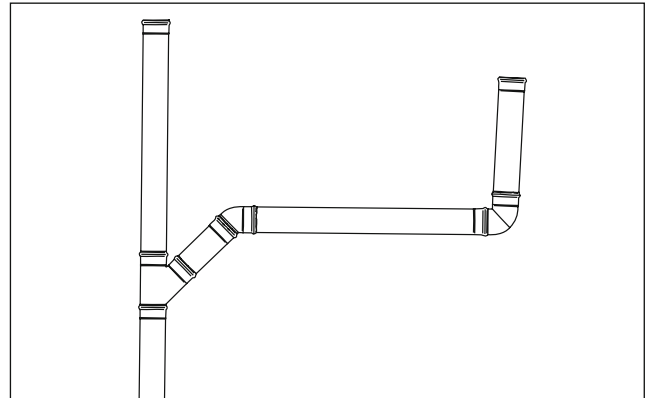

Fig. 5. Branch pipes with a minimum connection angle of 45° can be used when connecting ventilated side pipes.

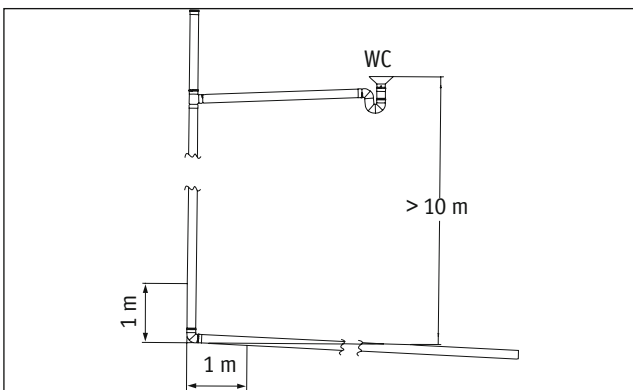

Fig. 6. No sanitary units should be connected closer than 1 m from the change of direction from vertical to horizontal pipes if a toilet is connected more than 10 m above the change in direction.

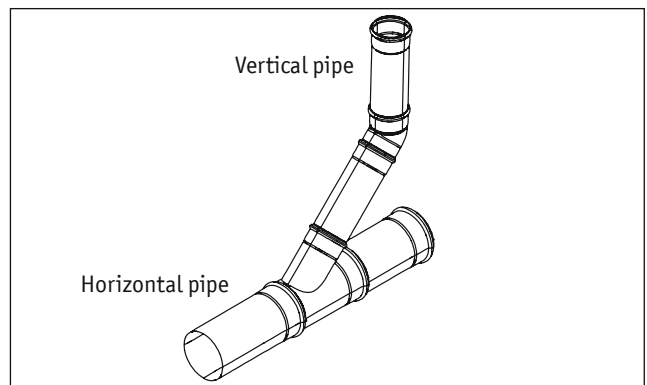

Fig. 8. A top connection can be used if the height of fall from the uppermost connected toilet is max. 9.5 m and max. three toilets are connected, but the arrangement shown in Fig. 9 is preferable.

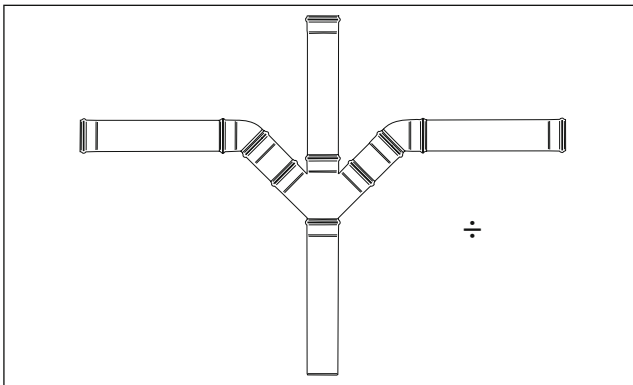

Fig. 7. Double branch pipes should not be used in horizontal lines.

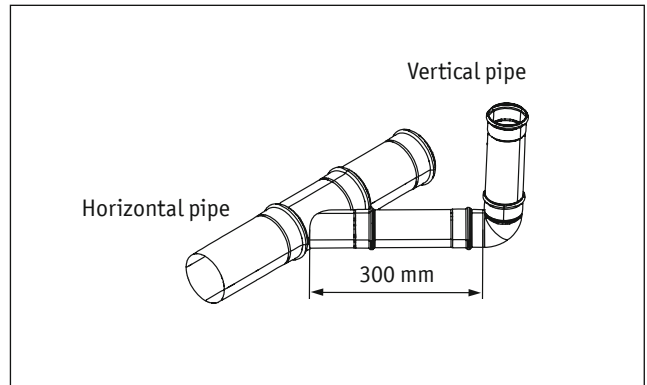

Fig. 9. For greater heights of fall and loadings, the vertical pipe should be connected via a straight horizontal pipe with a length of at least 0.3 m (side connection).

Joint Clamps

Drainage systems for soil, waste water and rainwater in above ground installations are gravity systems with free draining and should not be overloaded/blocked.

The BLÜCHER® EuroPipe drainage pipework system has push-fit sockets joints and consequently it will not be able to resist internal pressure unless precautions are made to ensure that the joints will not slide apart.

Appropriate fixing to the building can prevent the joints from sliding apart in most cases, but if it is difficult or impossible to fix the pipes to the building, joint clamps (type 847.xxx.xxx) can prevent the push-fit sockets and spigot ends from sliding apart if the system is overloaded or internal pressure is generated.



When installing the clamp joint please note that the two slices on the clamp should be at the socket end. Likewise, the one slice on the clamp should be located at the spigot end.

If installed incorrectly the clamp will have no function.

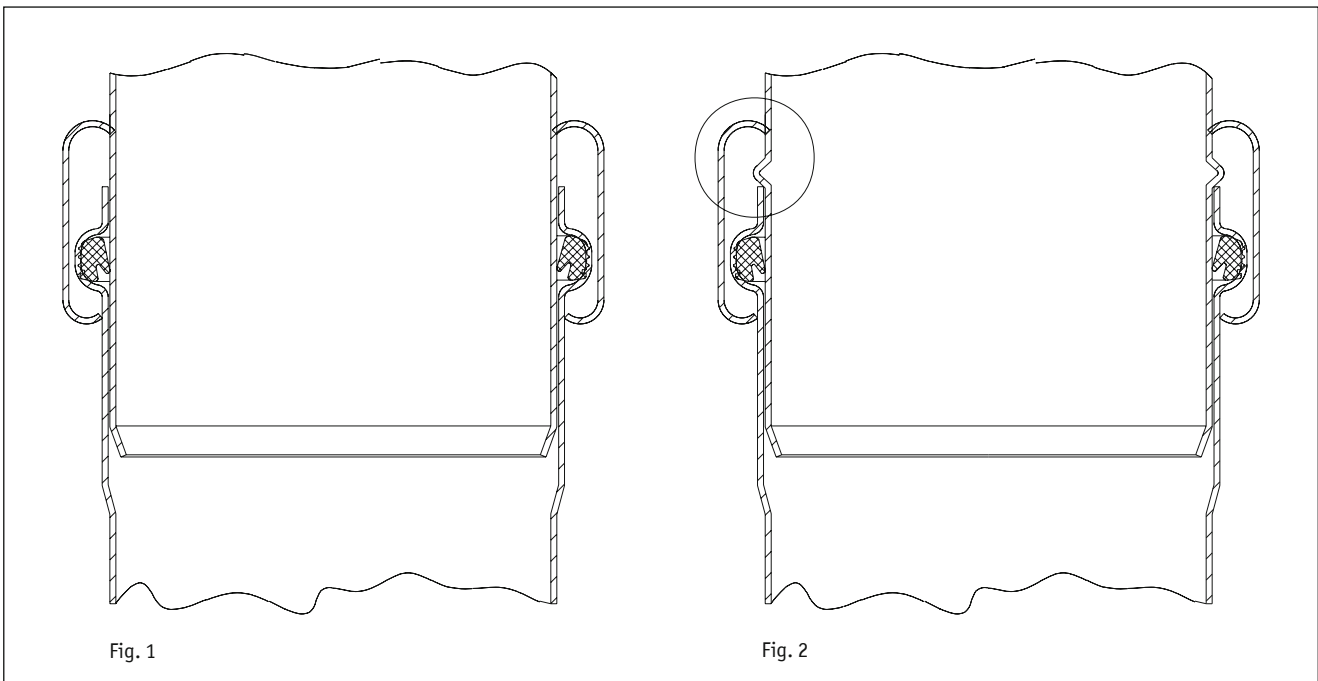

Fig. 1

Fig. 2

Joint clamps can be used in two ways:

They can simply be tightened (see Fig. 1), or the spigot end can be provided with projections for the clamps to grip (see Fig. 2).

The max. acceptable pressure depends on the method chosen. A joint with projections on the socket end can, as shown below, withstand a higher pressure than a joint without projections (pipes OD 50, 75, 82, 110, 125, 160, 200 and 250 mm).

Push-fit socket and spigot end **without** projections, with joint clamp type no. 847.xxx.xxx, can withstand the following pressures:

Pipe dimension	Max. pressure
ø 40 mm	+ 2 bar
ø 50 mm	+ 2 bar
ø 75 mm	+ 2 bar
ø 82 mm	+ 2 bar
ø110 mm	+ 2 bar
ø125 mm	+ 1 bar
ø160 mm	+ 1 bar
ø200 mm	+ 0,5 bar
ø250 mm	+ 0,2 bar
ø315 mm	N/A

Push-fit socket and spigot end **with** projections, with joint clamp type no. 847.xxx.xxx, can withstand the following pressures:

Pipe dimension	Max. pressure
ø 40 mm	N/A
ø 50 mm	+ 3 bar
ø 75 mm	+ 3 bar
ø 82 mm	+ 3 bar
ø110 mm	+ 3 bar
ø125 mm	+ 3 bar
ø160 mm	+ 3 bar
ø200 mm	+ 2,5 bar
ø250 mm	+ 2 bar
ø315 mm	N/A

Projections on the spigot end

Projections can be pressed on the spigot end of the pipe with a special tool before jointing with the socket end.

The projections can be pressed very quickly. When the spigot end has been mounted in the socket end, the joint clamp can be mounted in the usual way so that the part of the joint clamp holding the spigot end covers the projections (see Figure 2).

The tool consists of a set of special jaws for the electromechanical Mapress pressing tools types EFP 2, ECO 1 and ACO 1 (see Fig. 3).

It is important that the joints are completely tightened.

The table below shows the number of projections to be pressed on the pipe for the joint to be able to withstand 3 bar.

Pipe dimension	No. projections
ø 40 mm	N/A
ø 50 mm	2
ø 75 mm	4
ø 82 mm	4
ø110 mm	6
ø125 mm	8
ø160 mm	16
ø200 mm	16
ø250 mm	16
ø315 mm	N/A

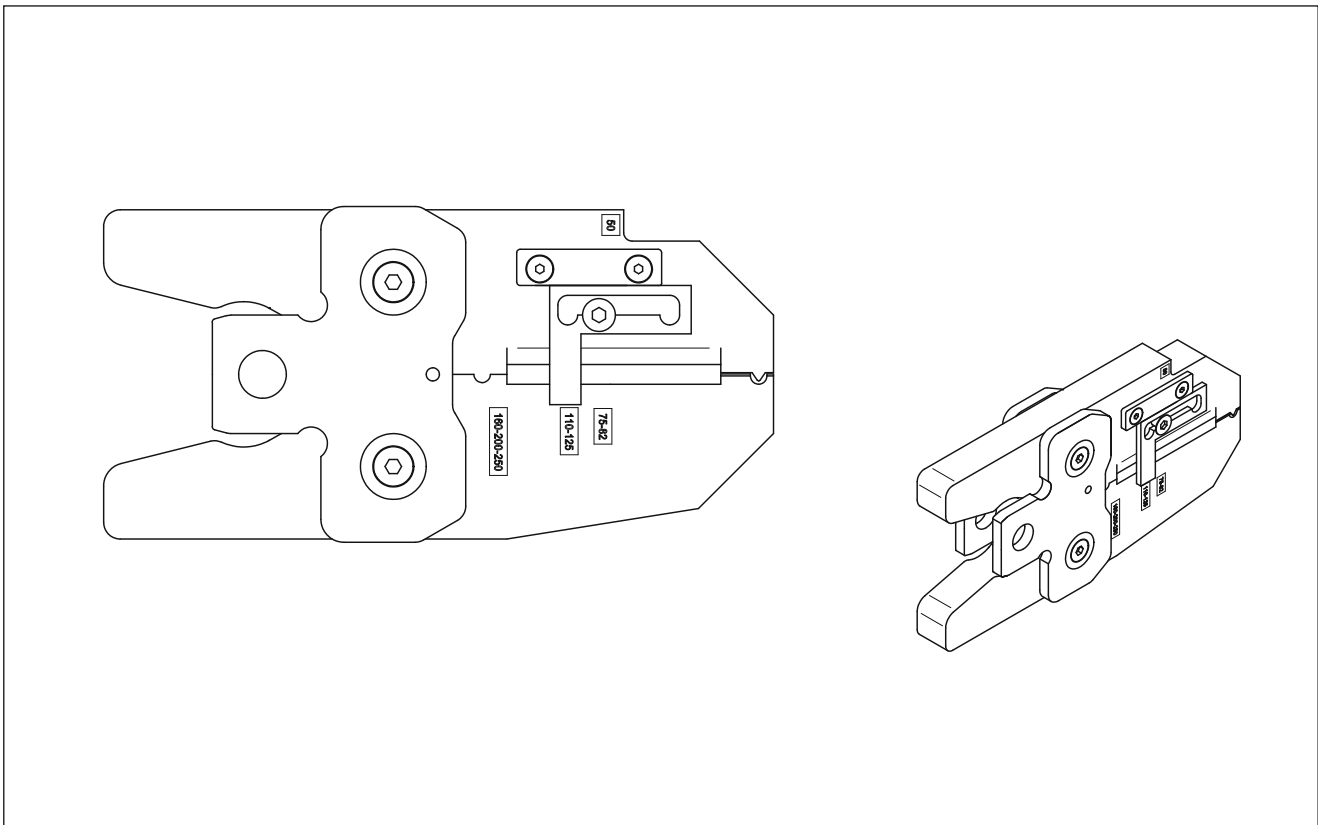

Fig. 3

Using socket plug clamps as access plugs

As stated above, drainage systems for waste water and rainwater in above-ground installations are gravity systems with free draining and should not be overloaded.

Under these conditions, joint clamps are not necessary to retain the access plugs in place. Actually, it is very difficult to remove the access plugs after the lubricant applied on the installation has been washed away, and using non-drying silicone as lubricant on these joints should be considered. However, if the access plugs are to be secured against being pushed out, e.g. as a result of an unforeseen blockage in the pipe system, socket plug clamps should be used.

■ TESTING/LEAKAGE TEST

Pipework systems can be tested for leakages using warning agents, e.g. peppermint oil or smoke, while creating an internal overpressure in the system with air. Where practically possible, a leakage test with air or water pressure can be used, and modified tests can be used for below-ground installations as described below. The test pressure can be 50000 Pa (0,5 bar) maintained for 15 minutes and there may be no leakage. Prior to testing it must be ensured that the system is properly fixed and joints will not slide apart.

Leakage testing should always be carried out on:

- Pipes and wells in waste water systems and in combined systems where damming often occurs.
- Pipes and wells near water catchment plants.
- Pipes and wells near water pipes where low pressure may occur, e.g. siphoning pipes.
- Pressure relief pipes.

The test

Leakage testing can be carried out before or after the final filling in of the excavation made for the pipes. The test should be carried out at a constant temperature. Pipes which have not been covered with earth must therefore be protected against temperature variations during the test. Direct sunshine on the pipe runs is not allowed.

Plug the pipes at each end of the test run and at all branches. Wells have to be sealed at the top and all inlets and outlets, as close as possible to the wall of the well, but including the joint between pipe and well in the test. All parts included in the system must be secured, and all seals must be designed in such a way that they will not become dislocated during the test.

Pipes and wells must be completely empty of water before the test. The test is then carried out with air or water.

Leakage test at BLÜCHER

All products are tested at BLÜCHER before leaving the factory.

The test is carried out with an air pressure of 0.5 bar.

Any leak will then be immediately evident.

Products are also tested at regular intervals with water pressure and vacuum by BLÜCHER and by independent approval authorities.

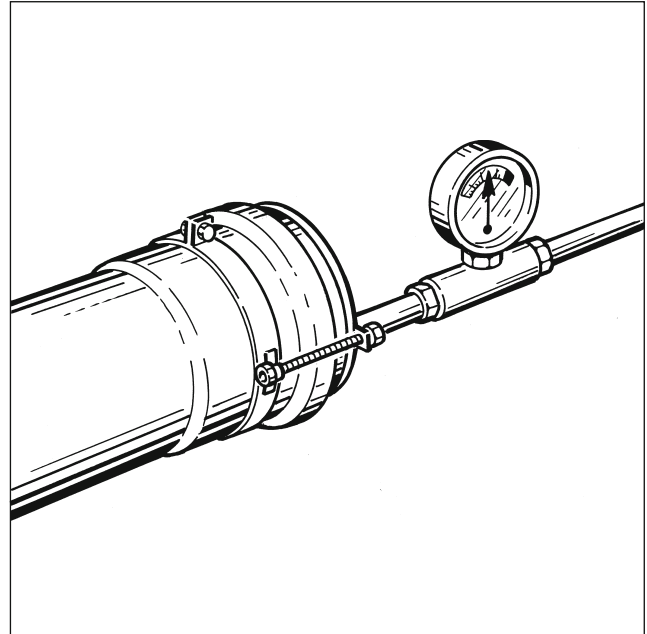

■ TRANSPORT, UNLOADING AND STORAGE

General:

All pipe shipments from BLÜCHER are cradled and packed on pallets. Fittings are packed in cardboard boxes and stacked on pallets. All goods are carefully packaged to avoid damage during transport.

Transport and handling

The following rules should be observed to avoid damage to pipes and fittings during transport.

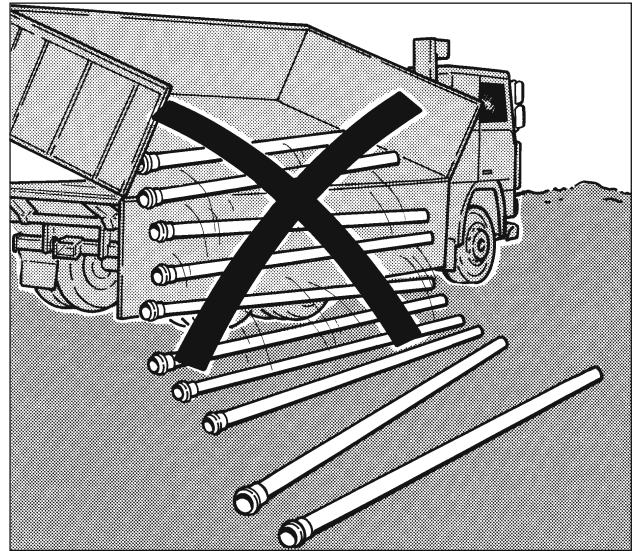

Pipes and fittings must not be dumped off trucks.

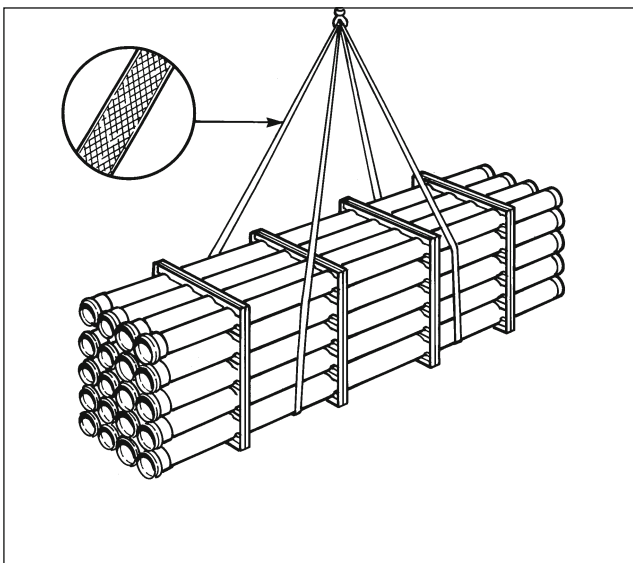

Support straps for loading and moving bundles of pipes by crane must be made of textile, canvas or similar material.

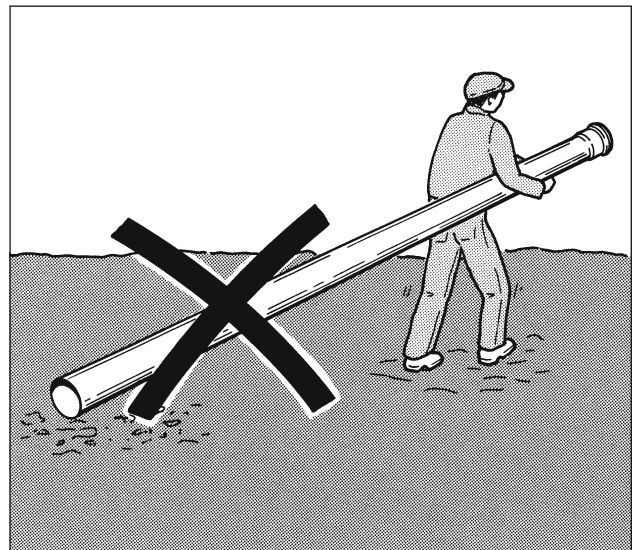

Pipes and fittings must not be dragged along the ground or other surfaces which could damage them.

Storage

To avoid deformation of, or serious damage to, pipes and fittings, we recommend storing the products in their original packaging until they are to be used.

Store pipes and fittings so that they do not come into contact with carbon steel, which can leave traces of corrosion on the stainless steel. Pipes and fittings must also be stored in a safe distance from sparks and spray from e.g. angle grinders and oxyacetylene torches.

Pipe bundles and loose pipes should be stored on a flat surface and supported so that the pipes do not rest on their sockets.

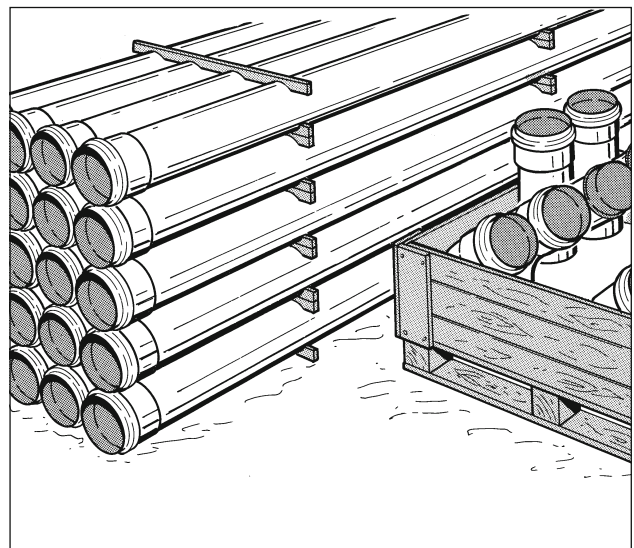

■ BLÜCHER® DRAINAGE SYSTEMS AND SOUND

Acoustics in sanitary drainage

Sound from drainage systems occurs when water passes through the pipes and causes movements in the pipework system and sometimes also in the building structure. The movements are transferred to the air in the room, causing sound. To be able to give the best possible advice regarding sound from drainage systems we have carried out measurements at the internationally recognised independent acoustics institute, Fraunhofer Institut in Stuttgart.

Tests have been carried out using Walraven SL simple two part pipe hanger when measuring sound from pipes and using BISMAT 1000 sound improved hanger in accordance with recommendations from Walraven when measuring sound to adjoining rooms.

Legislation

- The in Europe commonly used standard DIN 4109 states requirements of maximum 30 dB(A) through wall to adjoining rooms. In comparison the sound level in a library is 30 dB(A). BLÜCHER® EuroPipe complies with DIN 4109.
- EN 14366 states requirements to the test installation, but not any sound level requirements. BLÜCHER® EuroPipe has been tested in accordance with EN 14366 test requirements and complies with this standard.
- All materials have been tested in accordance with DIN 4109, and these results are shown in the diagrams. Compared to EN 14366 the results are approximately 3 dB(A) higher.

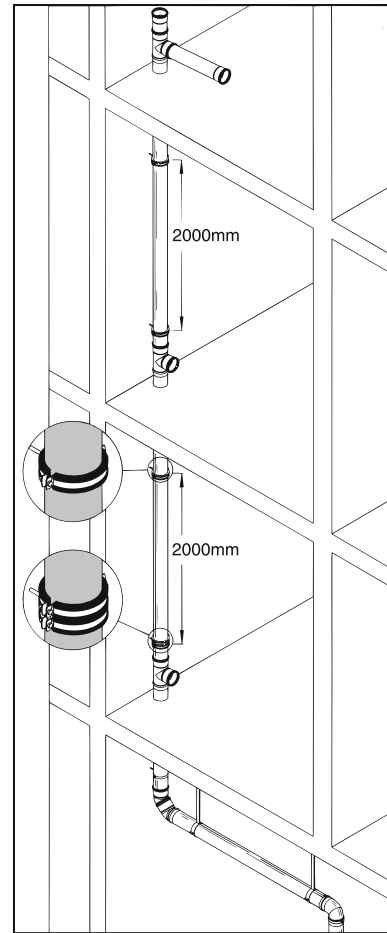

Test installation in accordance with EN 14366.
Top: SL simple two part hanger.
Bottom: BISMAT 1000 sound improved pipe hanger.

■ SOUND

Sound from drainage systems

Sound from drainage systems is influenced by a range of parameters. The acoustics of the surroundings, the water flow and the material used for the drainage system.

Sound from the pipes is created when:

- water and air meet
- water passes through a branch, a bend or a reducer

Sound spreads through the wall to adjoining rooms through:

- water
- pipe walls and pipe bends
- walls, floors and ceilings in buildings
- pipe brackets

Stainless steel and sound

BLÜCHER® EuroPipe in stainless steel is a lightweight, non-combustible and durable product complying with European Standard DIN 4109 and the requirements of this standard of max. 30 dB(A) to the adjoining room.

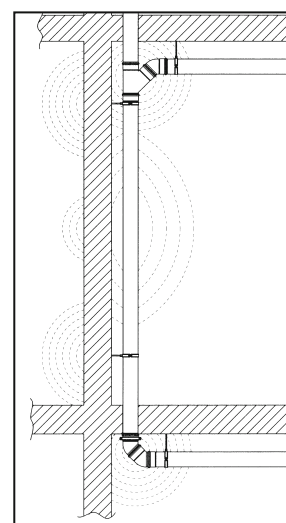

Sound dispersion

SOUND LEVEL MEASUREMENTS

Sound through wall to adjoining room

Sound through wall is measured in an adjoining room to the drainage installation. The tests were carried out using Walraven Bismat 1000 pipe hangers.

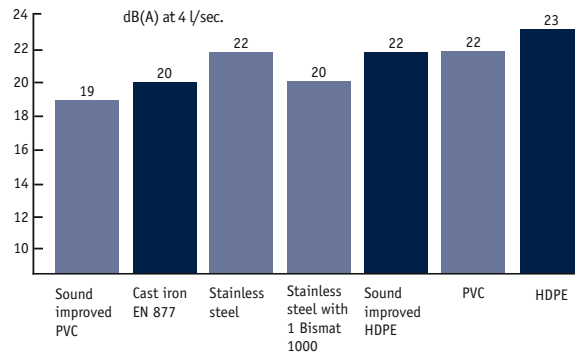

Sound from pipe

The graph to the right shows the sound level of various materials directly from the pipe at a water flow of 4 l/s, which is the highest flow tested and the most common flow in drainage installations. The tests were carried out using Walraven SL pipe hangers.

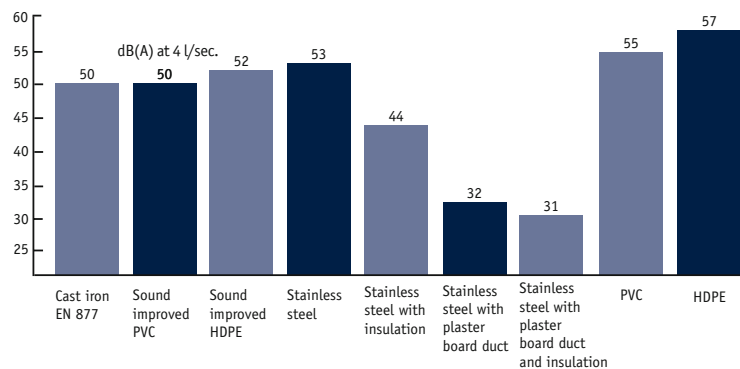

Sound reduction

Sound from pipes

If a reduction of sound from the pipes is requested, the best result is achieved by insulation. Either by insulating all pipes and bends or by building a duct around the pipes. The higher the density, the better reduction.

Sound through wall

If a reduction of sound to the adjoining room is requested, the type of pipe hanger and the quantity used is crucial. The less pipe hangers to transfer vibrations, the better reduction.

Only one pipe hanger per 3 metres

As opposed to plastic pipes, stainless steel pipes require only one pipe hanger per 3 metres, resulting in less sound and faster installation. If insulated pipe hangers like Bismat 1000 are used, an even better reduction of sound can be achieved.

Sound from pipes - reduction db(A)*	
Bismat 1000, 2 pcs. per storey	0
Bismat 1000, 1 pcs. per storey	0
Bismat 1000 and SL	0
Insulation	12
Plaster board duct, 2 layers	23
Plaster board duct, 2 layers with insulation	27
Brick-built duct	27

Sound through wall - reduction db(A)*	
Bismat 1000, 2 pcs. per storey	3
Bismat 1000, 1 pcs. per storey	11
Bismat 1000 and SL	7
Insulation	4
Plaster board duct, 2 layers with insulation	1
Brick-built duct	2

* SL pipe hangers are comparable with standard pipe hangers with rubber inlay. Bismat 1000 pipe hangers are sound-improved pipe hangers.

■ APPROVALS AND LABELLING

EN 1124

The BLÜCHER® EuroPipe system (pipes and fittings) is made, tested and checked under the EN standards

EN 1124-1 and EN 1124-2.

These two standards cover the following:

EN 1124-1 specifies requirements, tests and quality controls applying to pipes and fittings.

EN 1124-2 specifies requirements applying to pipe dimensions and dimensional tolerances for various fittings and pipes.

The above EN standards were prepared by the European standardisation organisation CEN. The BLÜCHER® EuroPipe system has thus obtained the recognized CE approval (CE marking).

These approvals serve as documentation that the approved product complies with all specified requirements.

Type approvals

BLÜCHER® EuroPipe has also been tested and approved in Norway, Sweden, Finland, England, Germany and Switzerland, and for ships and off-shore installations in accordance with Bureau Veritas, Lloyd's Register, DNV (Det Norske Veritas), Germanischer Lloyd, Rina (Registro Italiano Navale), and ABS (American Bureau of Shipping).

Labelling

Pipes and fittings

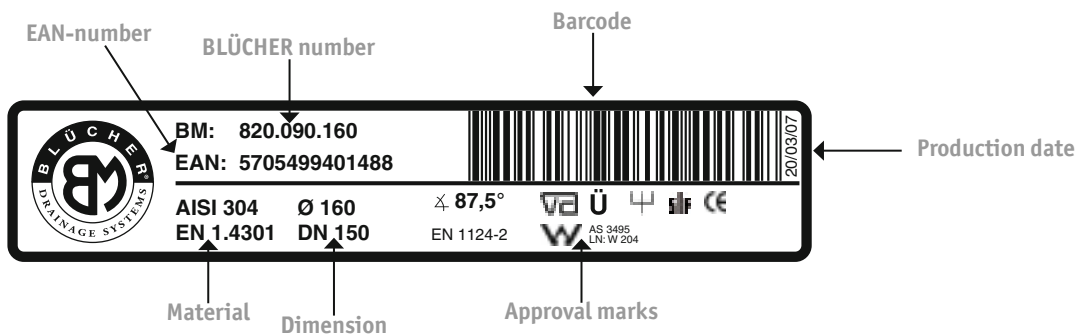

RED label = AISI 304, EN 1.4301

GREEN label = AISI 316L, EN 1.4404

■ EQUIPOTENTIAL BONDING

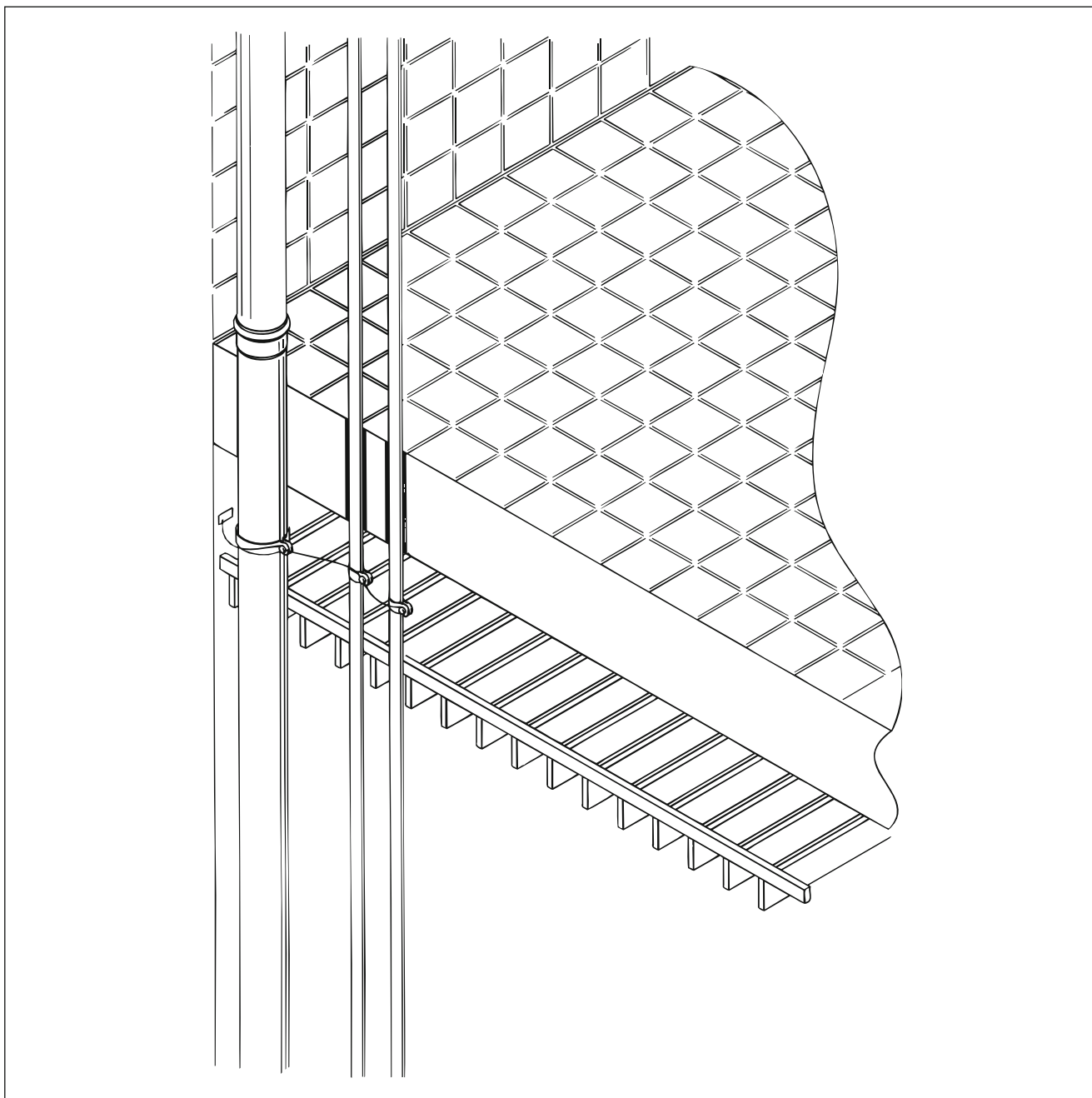

NOTE! The text below is for guidance only - always follow the current national regulations.

Equipotential bonding

Equipotential bonding is established as a main equalizer connection attached to the building.

In buildings with several flats, a supplementary equalizer connection is made in each flat. Installations and connections for equipotential bonding must be carried out by an electrician.

Consequently, the construction work must be coordinated in such a way that the electrician can establish the equipotential bonding before the pipe installation is covered.

Generally there are no requirements for establishment of equipotential bonding in connection with:

- replacement of water, heating or drainage installation
- repair of water, heating or drainage installation
- floor drains irrespective of material

BLÜCHER's stainless steel drainage pipes are joined with a push-fit socket. This joint is an electrical conductor and it can thus be used where the entire installation has to act as a conductor.

■ QUALITY ASSURANCE – ISO 9001

In the more than 35 years during which we at BLÜCHER have been developing and manufacturing stainless steel drainage systems, we have always done our best to make quality products, not merely from a design perspective, but equally from the perspective of function and durability.

BLÜCHER gives high priority to quality assurance, and all our production and quality assurance are in accordance with the internationally recognised ISO 9001 standard.

We operate with both external and internal quality assurance.

■ The ISO 9001 standard requires:

- the provision of documentation that controls are exercised at the level of administrative systems, development and design, purchasing, acceptance inspection, production, inspection of finished goods, stocks, sales, quality assurance and training.

■ External quality assurance

Several times a year, we have unannounced visits from representatives of Danish and foreign control bodies.

The auditors take a number of randomly selected pipes and fittings from our stocks or production and test them in accordance with the standards and approval criteria of the individual countries.

All control bodies are certified by the relevant national authorities to audit BLÜCHER's products.

■ Internal quality assurance

1. Internal quality control at BLÜCHER starts in the selection of our suppliers. All suppliers must be able to document their compliance with our requirements of quality and supply efficiency.
2. Every single delivery of stainless steel is accompanied by a material certificate, documenting the compliance of the stainless steel with the requirements specified by BLÜCHER.
3. All materials delivered to BLÜCHER must undergo admission checks. Only if the material delivered is in compliance with the requirements specified can it be passed on for production.
4. The stainless pipes are produced in a fully automated pipe mill. The sheet material, in the shape of coils, is introduced into the pipe mill, in which it is shaped by means of rollers into a pipe profile. The pipe is then welded with a longitudinal seam.
5. Upon welding, the longitudinal seam is checked with a circulating current device for detection of welding faults. In case of faults, the computer-controlled pipe mill automatically takes care of sawing out the defective pipe section and discarding it.
6. From the production department, all pipes and fittings proceed to the final surface treatment in the pickling plant. This surface treatment, tested by the Danish testing laboratory Korrosions-centralen, ensures that the pipes may be placed directly in the ground without additional protection.
7. During production of pipes and fittings, quality control takes place, which is meticulously registered in control journals. Before the fittings leave the production department, all elements are pressure-tested at 0.5 bar.
8. After the pickling, pipes and fittings proceed to the finishing department, where lip seals, among other things, are installed in the socket groove. At the same time, the elements are marked with approval markings, so that the elements may be identified at all times.
9. After finishing, pipes and fittings proceed to the central storage department. Here, the individual orders are packaged safely, in order to reach the customer undamaged.

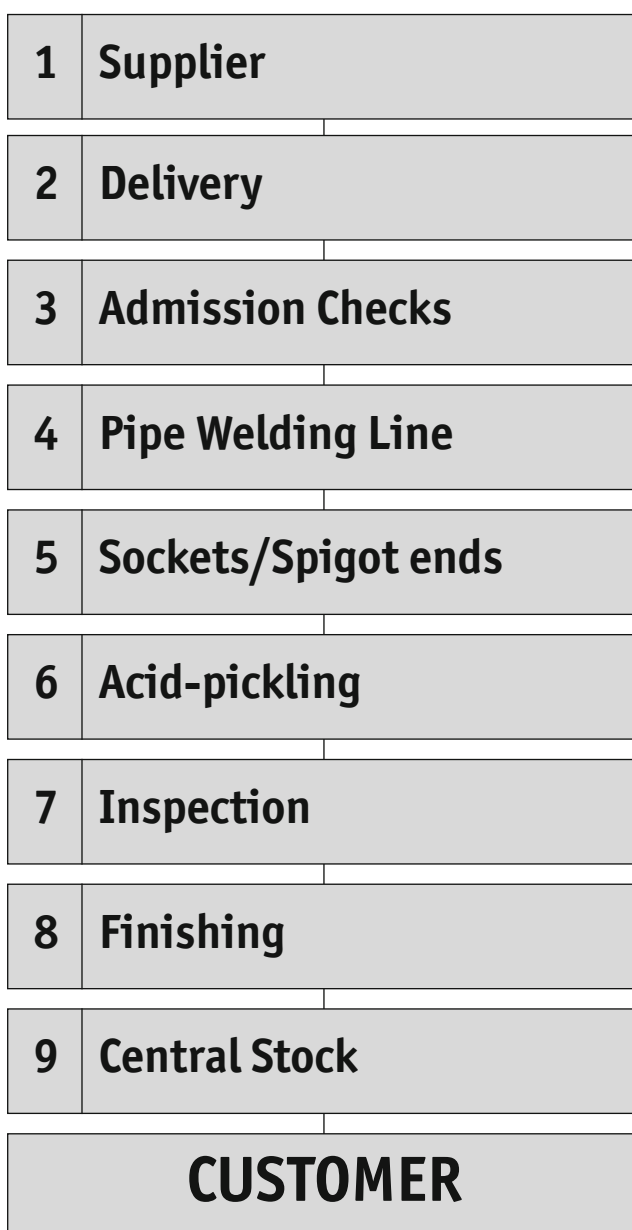

BLÜCHER® EuroPipe

BLÜCHER® Channel

BLÜCHER® Drain

BLÜCHER®

A WATTS Brand

T: +45 99 92 08 00 • export@blucher.com • blucher.com